

TM 11-6625-537-15

DEPARTMENT OF THE ARMY TECHNICAL MANUAL

OPERATOR,
ORGANIZATIONAL, FIELD,
AND DEPOT MAINTENANCE MANUAL

DIFFERENTIAL VOLTMETER ME-202/U

This copy is a reprint which includes current
pages from Canges 1 through 3.

HEADQUARTERS, DEPARTMENT OF THE ARMY
DECEMBER 1962

TECHNICAL MANUAL
DIFFERENTIAL VOLTMETER ME-202/U

TM 114625-537-15 }
CHANGES No. 1 }

HEADQUARTERS,
DEPARTMENT OF THE ARMY
WASHINGTON 25, D.C., 6 May 1963

TM 11-6625-537-15, 23 December 1962, is changed as follows:

Page 1-1. Add paragraphs 1-1.1 and 1-1.2 after paragraph 1-1.

1-1.1. Index of Publications

Refer to the latest issue of DA Pam 3104 to determine whether there are new editions, changes, or additional publications pertaining to your equipment. DA Pam 310-4 is a current index of technical manuals, technical bulletins, supply bulletins, lubrication orders, and modification work orders that are available through publications supply channels. The index lists the individual parts (-10, -20, -35P, etc) and the latest changes to and revisions of each equipment publication.

1-1.2. Forms and Records

a. *Reports of Maintenance and Equipment*

Improvement Recommendations. Use equipment forms and records in accordance with instructions in TM 38-750.

b. *Report of Damaged or Improper Shipment.* Fill out and forward DD Form 6 (Report of Damaged or Improper Shipment) as prescribed in AR 700-58 (Army), NAVSANDA Publication 378 (Navy), and AFR 71-4 (Air Force).

c. *Comments on Manual.* Forward all comments on this publication direct to: Commanding Officer, U.S. Army Electronics Materiel Support Agency, ATTN: SELMS-MP, Fort Monmouth, N. J. DA Form 2028 (Recommended changes to DA Technical Manual Parts Lists or Supply Manual 7, 8 or 9) will be used.

Page 2-4. Add section II.1 after section II.

Section II.1. ORGANIZATIONAL MAINTENANCE INSTRUCTIONS

2.1-1. Scope of Organizational Maintenance

The maintenance duties assigned to the organizational repairman are listed below, together with a reference to the paragraphs covering the specific maintenance function. The duties assigned do not require tools or test equipment other than those issued with the unit.

a. Daily maintenance service and inspection (par. 2.1-4).

b. Weekly maintenance service and inspection (par. 2.1-5).

c. Monthly maintenance service and inspection (par. 2.1-7).

d. Cleaning (par. 2.1-8).

e. Painting (par. 2.1-9).

2.1-2. Materials Required

a. Sandpaper.

b. Paint and brush.

2.1-3. Organizational Preventive Maintenance

Organizational preventive maintenance is the systematic care, servicing, and inspection of equipment to prevent the occurrence of trouble, to reduce downtime, and to assure that the equipment is serviceable. Preventive maintenance is the responsibility of all echelons concerned with the equipment and also includes the testing and repair or replacement of parts that inspection and tests indicate would probably fail before the next scheduled periodic service.

a. *Systematic Care.* The procedures given in paragraphs 2.1-4, 2.1-5, and 2.1-7 cover systematic care essential to proper upkeep and operation of the equipment. The cleaning operations (par. 2.1-8) should be performed once a day. If the equipment is not used daily, however, the cleaning operations must be performed before operation after any extended shutdown, or once a week while the equipment is kept in *standby* con-

dition. The other items must be checked before the equipment is placed in operation after a shut-down, during operation, or after it is turned off, as specified in the applicable paragraph.

b. Maintenance Service and Inspection. The daily, weekly, and monthly maintenance service and inspection charts (par. 2.1-4, 2.1-5, and 2.1-7) outline inspections to be made at daily, weekly, and monthly intervals. These inspections are made to determine combat serviceability; that is, to determine that the equipment is in good general (physical) condition, in-good operating condition,

and likely to remain combat serviceable. To assist the organizational repairman in determining and maintaining combat serviceability, the charts indicate what to inspect, how to inspect, and what the normal conditions are. The *References* columns in the maintenance service and inspection charts list the paragraphs that contains additional information. If the defect cannot be remedied by the operator, higher echelon maintenance or repair is required. Records and reports of these inspections must be made in accordance with TM 33-750.

2.1-4. Daily Maintenance Service and Inspection Chart

Item No.	Procedures		References
	Item	Normal condition or result	
1	SET: Inspect the equipment for completeness, cleanliness, and proper installation.	Equipment must be complete, clean, and installed for operation.	Par. 2.1-8.
4	KNOBS, DIALS, and SWITCHES: Check for proper mechanical action by setting each control to each of its possible settings.	Action is positive, without backlash, binding, or scraping.	
5	METER WINDOW: Inspect meter window for chipped, cracked, or broken glass.	Meter window must be clean and in good condition.	
12	OPERATION: Perform the preliminary operation procedures (par. 2-2) and be alert for unusual indications during operation.	As stated in paragraph 2-2.	

2.1-5. Weekly Maintenance Service and Inspection Chart

Item No.	Procedures		References
	Item	Normal condition or result	
1	SET: Inspect the equipment for preservation.	Painted surfaces must be free of bare spots, rust, and corrosion.	Par. 2.1-9.
6	POWER CORD: Inspect power cord for cracks, strain, fraying, or deterioration.	Power cord must be in apparently good condition.	Tape damaged areas.
7	HARDWARE: Inspect all exterior hardware for looseness and damage.	Meter cover, input binding posts, carry handle, mounts, and all bolts and screws must be tight and not damaged.	Tighten loose hardware.

2.1-6. Monthly Maintenance

a. A month is defined as approximately 30 calendar days of 8-hour-per-day operation. If the equipment is operated 16 hours a day, the monthly maintenance should be performed at 15-day intervals. Adjustment of the maintenance interval must be made to compensate for any unusual operating conditions. Equipment maintained in standby (ready for immediate operation) condition must have monthly maintenance performed on it.

b. Monthly maintenance will be scheduled in accordance with the requirements in TM 38-750.

All deficiencies or shortcomings will be recorded, and those not corrected during the inspection and service will be immediately reported to higher echelon by use of forms and procedures specified in TM 38-750. Equipment which has a deficiency that cannot be corrected by second echelon should be deadlined in accordance with TM 38-750. Perform all the services listed in the monthly maintenance service and inspection chart (par. 2.1-7) in the sequence listed. Whenever a normal condition or result is not observed, take corrective action with the information listed in the *References* column.

2.1-7. Monthly Maintenance Service and Inspection Chart

Item No.	Procedures		References
	Item	Normal condition or result	
1	SET: Inspect the equipment for: a. Completeness..... b. Proper installation..... c. Cleanliness..... d. Preservation.....	a. Equipment must be complete. b. Equipment must be properly installed. c. The unit must be clean and dry inside and out, and free of grease, dirt, rust, corrosion, and fungus. d. Painted surfaces must be free of bare spots, rust, and corrosion.	c. Par. 2.1-8. d. Par. 2.1-9.
2	PUBLICATIONS: Check to see that pertinent publications are available.	a. Operator's, organizational, field, and depot maintenance manual must be complete and in usable condition, without missing pages. b. All changes pertinent to the equipment are on hand.	b. DA Pam 310-4 for requirements.
3	MODIFICATION WORK ORDERS: Check DA Pam 310-4 to determine if new applicable MWO's have been published.	All URGENT MWO's have been applied to the equipment. All ROUTINE MWO's have been scheduled.	Par. 1-1.1.
4	KNOBS, DIALS, and SWITCHES: Check for proper mechanical action by setting each control to each of its possible settings.	Action is positive, without backlash, binding, or scraping. <i>Note.</i> Knobs that require frequent tightening should have set screws replaced.	
5	METER WINDOW: Inspect meter window for chipped, cracked, or broken glass.	Meter window must be clean and in good condition.	
6	POWER CORD: Inspect power cord for cracks, strain, fraying, or deterioration.	Power cord must be in apparently good condition.	Tape damaged areas.
7	HARDWARE: Inspect all exterior and interior hardware for looseness and damage.	Meter cover, input binding posts, carry handle, mounts, insulators, terminal boards, and all bolts and screws must be tight and not damaged.	Tighten loose hardware.
8	INTERIOR COMPONENTS: Inspect wiring, capacitors, resistor, diodes, transistors, transformer, and dry cells for cracks, leaks, blistering, or other detrimental defects.	Wiring, capacitors, resistors, diodes, transistor, transformer, and dry cells show no evidence of physical, heat, or electrical damage.	
9	PLUCKOUT ITEMS: Inspect clamps and seatings of pluckout items.	All pluckout items should be properly seated, and clamps in proper position and correctly tightened.	
10	FUSE: Check for proper fuse.....	The power fuse in use should be of the value indicated below: a. 117-vac operation: 3 amperes. b. 220-vac operation: 1½ amperes. c. 234-vac operation: 1½ amperes.	
11	LUBRICATION: Perform lubrication as directed in paragraph 4-2d.	As stated in paragraph 4-2d.....	Par. 4-2d.
12	OPERATION: Perform the preliminary procedures (par. 2-2) and be alert for unusual indications during operation.	As stated in paragraph 2-2.....	Pars. 2-1 and 2-2.
13	SPARE PARTS: Check all spare parts (operator and organizational) for general condition and method of storage.	All spare parts must be in good condition and properly stored. There should be no evidence of overstock, and all shortages will be on valid requisitions.	

2.1-8. Cleaning

Inspect the exteriors of the receiver, the transmitter, and the remote unit. The exterior surfaces should be clean, and free of dust, dirt, grease, and fungus.

a. Remove dust and loose dirt with a clean soft cloth.

Warning: Cleaning compound is flammable and its fumes are toxic. Provide adequate ventilation. Do not use near a flame.

b. Remove grease, fungus, and ground-in dirt from the cases; use a cloth dampened (not wet) with Cleaning Compound (Fed. stock No. 7930-395-9542).

c. Remove dust or dirt from plugs and jacks with a brush.

Caution: Do not press on the meter faces (glass) when cleaning; the meter may be damaged.

d. Clean the front panels, meters, and control knobs; use a soft clean cloth. If necessary, dampen

the cloth with water; mild soap may be used to make the cleaning more effective.

2.1-9. Painting

Clean rust and corrosion from metal surfaces by lightly sanding them with fine sandpaper. Brush two thin coats of paint on the bare metal to protect it from further corrosion. Refer to the applicable cleaning and refinishing practices specified in TM 9-213, Painting Instructions for Field Use.

Page 5-11. Add appendix after section V.

APPENDIX REFERENCES

DA Pam 310-4 Index of Technical Manuals, Technical Bulletins, Supply Bulletins, Lubrication Orders, and Modification Work Orders.	TM 9-213	Painting Instructions for Field use.
	TM 38-750	The Army Equipment Record System and Procedures.

By Order of the Secretary of the Army:

EARLE G. WHEELER,
*General, United States Army,
Chief of Staff.*

Official:

J. C. LAMBERT,
*Major General, United States Army,
The Adjutant General*

Distribution:

Active Army:

DASA (6)
USASA (2)
CNGB (1)
CofEngrs (1)
TSG (1)
CSigO (5)
CofT (1)
USA CD Agcy (1)
USCONARC (5)
USAMC (5)
ARADCOM (2)
ARADCOM Rgn (2)
OS Maj Cored (3)
OS Base Cored (2)
LOGCOMD (2)
USAECOM (5)
USAMICOM (3)
USASCC (4)
MDW (1)
Armies (2)
Corps (2)
USA Corps (3)
USATC AD (2)
USATC Engr (2)
USATC Inf (2)
USATC Armor (2)
Inatl (2) except
 Ft Monmouth (63)
Svc colleges (2)
Br Svc Sch (2)
GENDEP (OS) (2)

NG: State AG (3).

USAR: None.

For explanation of abbreviation used, see AR 320-50.

Sig Dep (OS) (12)
Sig Sec, GENDEP (5)
Army Dep (2) except
 Ft Worth (8)
 Lexington (12)
 Sacramento (17)
 Tobyhanna (12)
USA Elct RD Actv, White Sands (13)
USA Elct RD Actv, Ft Huachuca (2)
USA Trans Tml Comd (1)
Army Tml (1)
POE (1)
OSA (1)
AMS (1)
WRAMC (1)
AFIP (1)
Army Pic Cen (2)
USA Mbl Spt Cen (1)
USA Elct Mat Agcy (25)
Chicago Proc Dist (1)
USARCARIB Sig Agcy (1)
Sig Fld Maint Shops (3)
JBUSMC (2)
Units organized under following TOE
(2 cy ea UNOINDC)
 11-7 11-157
 11-16 11-500 AA-AC (4)
 11-57 11-557
 11-97 11-587
 11-98 11-592
 11-117 11-597
 11-155

Changes in force: C 1 and C 2

TM 11-6625-537-15
C 2

Operator, Organizational, Field, and Depot Maintenance Manual
VOLTMETER, ELECTRONIC ME-202/U

CHANGE }
No. 2 }

Headquarters
Department of the Army
WASHINGTON, D. C. 21 January 1964

TM 11-8625-537-15, 23 December 1962, is changed as follows:

Change the title of the manual as shown above.

Note. The parenthetical reference to previous changes (example: page 1 of C1) indicate that pertinent material was published in that change.

Page 1-1, paragraph 1-1.2 (page 1 of C1). Delet subparagraph *c* and substitute:

c. Reporting of Equipment Manual Improvements. The direct reporting by the individual user, of errors, omissions, and recommendations for improving this manual is authorized and encouraged. DA Form 2028 (Recommended changes to DA technical manual parts lists or supply manual 7, 8, or 9) will

be used for reporting these improvements. This form will be completed in triplicate using pencil, pen, or typewriter. The original and one copy will be forwarded direct to Commanding Officer, U.S. Army Electronics Materiel Support Agency, ATTN: SELMS-MP, Fort Monmouth, N. J. 07703. One information copy will be furnished to the individual's immediate supervisor (officer, noncommissioned officer, supervisor, etc.).

Page 5-11, appendix (page 4 of C1). Designate "appendix" as: appendix I.

Add appendixes II and III after appendix I.

APPENDIX II

MAINTENANCE ALLOCATION

Section 1. INTRODUCTION

1. General

a. This appendix assigns maintenance functions to be performed on components, assemblies, and subassemblies by the lowest appropriate maintenance echelon.

b. Columns in the maintenance allocation chart are as follows:

- (1) *Part or component.* This column shows only the nomenclature or standard item name. Additional descriptive data are included only where clarification is necessary to identify the component. Components, assemblies, and subassemblies are listed in top-down order. That is, the assemblies which are part of a component are listed immediately below that component, and the subassemblies which are part of an assembly are listed immediately below that assembly. Each generation breakdown (components, assemblies, or subassemblies) is listed in disassembly order or alphabetical order.
- (2) *Maintenance function.* This column indicates the various maintenance functions allocated to the echelons.
 - (a) *Service.* To clean, to preserve, and to replenish lubricants.
 - (b) *Adjust.* To regulate periodically to prevent malfunction.
 - (c) *Inspect.* To verify serviceability and to detect incipient electrical or mechanical failure by scrutiny.
 - (d) *Test.* To verify serviceability and to detect incipient electrical or mechanical failure by use of special equipment such as gages, meters, etc.
 - (e) *Replace.* To substitute serviceable components, assemblies, or subas-

semblies, for unserviceable components, assemblies, or subassemblies.

- (f) *Repair.* To restore an item to serviceable condition through correction of a specific failure or unserviceable condition. This function includes but is not limited to welding, grinding, riveting, straightening, and replacement of parts other than the trial and error replacement of running spare type items such as fuses, lamps, or electron tubes.
- (g) *Align.* To adjust two or more components of an electrical system so that their functions are properly synchronized.
- (h) *Calibrate.* To determine, check, or rectify the graduation of an instrument, weapon, or weapons system, or components of a weapons system.
- (i) *Overhaul.* To restore an item to completely serviceable condition as prescribed by serviceability standards. This is accomplished through employment of the technique of "Inspect and Repair Only as Necessary" (IROAN). Maximum utilization of diagnostic and test equipment is combined with minimum disassembly of the item during the overhaul process.
- (j) *Rebuild.* To restore an item to a standard as near as possible to original or new condition in appearance, performance, and life expectancy. This is accomplished through the maintenance technique of complete disassembly of the item, inspection of all parts or components, repair or replacement

of worn or unserviceable elements using original manufacturing tolerances and/or specifications and subsequent reassembly of the item.

- (3) *1st, 2d, 3d, 4th, and 5th echelons.* The symbol X indicates the echelon responsible for performing that particular maintenance operation, but does not necessarily indicate that repair parts will be stocked at that level. Echelons higher than the echelon marked by X are authorized to perform the indicated operation.
- (4) *Tools required.* This column indicates codes assigned to each individual tool equipment, test equipment, and maintenance equipment referenced. The grouping of codes in this column of the maintenance allocation chart indicates the tool, test, and maintenance equipment required to perform the maintenance function.
- (5) *Remarks.* Entries in this column will be utilized when necessary to clarify

any of the data cited in the preceding column.

c. Columns in the allocation of tools for maintenance functions are as follows:

- (1) *Tools required for maintenance functions.* This column lists tools, test, and maintenance equipment required to perform the maintenance functions.
- (2) *1st, 2d, 3d, 4th, 5th echelon.* The dagger (†) symbol indicates the echelons normally allocated the facility.
- (3) *Tool code.* This column lists the tool code assigned.

2. Maintenance by Using Organizations

When this equipment is used by signal services organizations organic to theater headquarters or communication zones to provide theater communications, those maintenance functions allocated up to and including fourth echelon are authorized to the organization operating this equipment.

SECTION II. MAINTENANCE ALLOCATION CHART

PART OR COMPONENT	MAINTENANCE FUNCTION	ECHOSON					TOOLS REQUIRED	REMARKS
		1	2	3	4	5		
VOLTMETER ELECTRONIC ME-202/U	service	X						
	adjust					X		
	inspect	X						
	test					X	1 thru 14	
	replace					X	8,9	
	repair					X	8,9	
	calibrate					X	1,2,3,4,5,6,10,12,13	D.C. and A.C. Calibration.
rebuild					X	14	DEPOT FACILITIES.	

SECTION III. ALLOCATION OF TOOLS FOR MAINTENANCE FUNCTIONS

PART OR COMPONENT	ECHELON					TOOL CODE	PROC SERV	TYPE CLASS	REMARKS
	1	2	3	4	5				
ME-202/U (continued)									
AUDIO OSCILLATOR TS-421/U						† 1	ARMY	A	
GALVANOMETER, L&N No. 2430C OR EQUAL INSTRUMENT CALIBRATION STANDARD						† 2			5th Echelon only.
WESTON MODEL 61 OR RFL TYPES 1900 & 1967						† 3			5th Echelon only.
PINCH TYPE SWITCH L&N 3294						† 4			5th Echelon only.
POTENTIOMETER, L&N NO. K-2 OR EQUAL						† 5			5th Echelon only.
STANDARD CELL, EPFLEY No. 10CA OR EQUAL						† 6			5th Echelon only.
TEST SET, TRANSISTOR, TS-1836/U						† 7			
TOOL KIT, RADAR & RADIO REPAIRMAN TK-87/U						† 8	ARMY	A	
TOOL KIT, SUPPLEMENTAL RADAR AND RADIO REPAIRMAN TK-88/U						† 9	ARMY	A	
TRANSFORMER, VARIABLE CN-16/U						† 10	ARMY	A	
TUBE TESTER, ELECTRON TUBE TV-2/U						† 11	ARMY	A	
VOLTTMETER TRANSFER, HERMACH ENGELHARD						† 12			
VOLT BOX, L&N No. 7592						† 13			
VOLTMETER, METER ME-30/U						† 14	ARMY	A	

APPENDIX III

BASIC ISSUE ITEMS LIST

Section I. INTRODUCTION

1. General

This appendix lists items supplied for initial operation and for running spares. The list includes tools, parts, and material issued as part of the major end item. The list includes all items authorized for basic operator maintenance of the equipment. End items of equipment are issued on the basis of allowances prescribed in equipment authorization tables and other documents that are a basis for requisitioning.

2. Columns

Columns are as follows:

a. Federal Stock Number. This column lists the 11-digit Federal stock number.

b. Designation by Model. Not used.

c. Description. Nomenclature or the standard item name and brief identifying data for each item are listed in this column. When req-

uisitioning, enter the nomenclature and description.

d. Unit of Issue. The unit of issue is each unless otherwise indicated and is the supply term by which the individual item is counted for procurement, storage, requisitioning, allowances and issue purposes.

e. Expendability. Nonexpendable items are indicated by NX, Expendable items are not annotated.

f. Quantity Authorized. Under "Items Comprising an Operable Equipment," the column lists the quantity of items supplied for the initial operation of the equipment. Under "Running Spare Items" the quantities listed are those issued initially with the equipment as spare parts. The quantities are authorized to be kept on hand by the operator for maintenance of the equipment.

g. Illustration. Not used.

SECTION II. FUNCTIONAL PARTS LIST

FEDERAL STOCK NUMBER	DESIGNATION BY MODEL	DESCRIPTION	UNIT OF ISSUE	EXP	QTY AUTH	ILLUSTRATION		
						FIGURE NO.	ITEM NO.	
6625-050-8686		VOLTMETER ELECTRONIC ME-202/U: ranges and quantity of steps; ± 0.1 to ± 500 vdc in 8 steps, ± 0.01 to 0.500 vac in 8 steps accuracy; $\pm 0.05\%$ on dc ranges $\pm 2\%$ accuracy on ac ranges. Input impedance data electronic type; $1m$ to $10m$ on dc voltage range $1m$ 25 uuf power regt; ac $117/234v$, $50/60$ cps single ph. o/a dim $9-3/4$ in x 13 in by 17 in metal case w/baked enameled finish-Mfg data John Fluke Mfg Co, Inc. 1111 W. Nickerson ST, Seattle 99, Wash. Model 803	1	NX				R
		ITEMS COMPRISING AN OPERABLE EQUIPMENT						
	ORD THRU AGC	TECHNICAL MANUAL TM 11-6625-537-15			2			R
		RUNNING SPARE ITEMS						
5960-505-0273		ELECTRON TUBE: Ampres p/n 003/85A2			2			R
5905-755-0832		ELECTRON TUBE, CURRENT REGULATOR; Amperite p/n 9-7			1			R
5960-557-6883		ELECTRON TUBE: MIL type 0A2			1			R
5960-166-7648		ELECTRON TUBE: MIL type 0B2			1			R
5960-300-1141		ELECTRON TUBE: MIL type 5Y3GT			1			R
5960-631-1430		ELECTRON TUBE: MIL type 6AQ5A			1			R
5960-617-4920		ELECTRON TUBE: MIL type 6AU6			1			R
5960-615-4745		ELECTRON TUBE: MIL type 6AW8			1			R
5960-188-8515		ELECTRON TUBE: MIL type 6C4			1			R
5960-800-0549		ELECTRON TUBE: MIL type 6DK6			1			R
5960-166-7661		ELECTRON TUBE: MIL type 6X4			1			R
5905-166-7663		ELECTRON TUBE: MIL type 12AU7			1			R
5960-166-7664		ELECTRON TUBE: MIL type 12AX7			1			R
5960-239-3052		ELECTRON TUBE: MIL type 5881			1			R

FEDERAL STOCK NUMBER	DESIGNATION BY MODEL	DESCRIPTION	UNIT OF ISSUE	EXP	QTY AUTH	ILLUSTRATION	
						FIGURE NO.	ITEM NO.
5920-010-6652 6240-577-8456		ME-202/U (continued) FUSE, CARTRIDGE: 3 amp, 250v Littlefuse p/n 312103 LAMP, GLOW: GE p/n NE2E			1 1		

R
R

ME-202/U

By Order of the Secretary of the Army:

EARLE G. WHEELER,
General, United States Army,
Chief of Staff

Official:

J. C. LAMBERT,
Major General, United States Army.
The Adjutant General.

Distribution:

To be distributed in accordance with DA Form 12-31 requirements for Organizational Maintenance Instructions, OV-1 Aircraft.

Changes in force: C 1, C 2, and C 3

TM 11-6525-537-15

C 3

CHANGE }
No. 3 }

HEADQUARTERS
DEPARTMENT OF THE ARMY
WASHINGTON, D.C., 14 February 1974

**Operator, Organizational, Field,
and Depot Maintenance Manual
VOLTMETER, ELECTRONIC ME-202/U**

TM 11-6625-537-15, 23 December 1962, is changed as follows:

Page 1-1, paragraph 1-1.1. Delete paragraph 1-1.1 and substitute:

1-1.1. Indexes of Publications

a. DA Pam 320-4. Refer to the latest issue of DA Pam 310-4 to determine whether there are new editions, changes, or additional publications pertaining to the equipment.

b. DA Pam 310-7. Refer to the DA Pam 310-7 to determine whether there are modification work orders (MWO's) pertaining to the equipment.

Paragraph 1-1.2. Delete paragraph 1-1.2 and substitute:

1-1.2. Forms and Records

a. *Reports of Maintenance and Unsatisfactory Equipment.* Maintenance forms, records, and reports which are to be used by maintenance personnel at all maintenance levels are listed in and prescribed by TM 38-750.

b. *Reporting of Packaging and Handling Deficiencies.* Fill out and forward DD Form 6 (Report of Packaging and Handling Deficiencies)

as prescribed in AR 700-58 (Army)/NAVSUP PUB 378 (Navy)/AFR 71-4 (Air Force)/MCO P4030.29 (Marine Corps), and DSAR 4145.8.

c. *Discrepancy in Shipment Report (DISREP) (SF 361).* Fill out and forward Discrepancy in Shipment Report (DISREP) (SF 361) as prescribed in AR 55-38 (Army)/NAVSUPINST 4610.33/AFM 75-18/MCO P4610.19A (Marine Corps), and DSAR 4500.15.

1-1.3. Reporting of Errors

The reporting of errors, omissions, and recommendations for improving this publication by the individual user is encouraged. Reports should be submitted on DA Form 2028, Recommended Changes to Publications, and forwarded direct to Commander, US Army Electronics Command, ATTN: AMSEL-MA-C Fort Monmouth, NJ 07703.

1-1.4. Items Comprising an Operable Voltmeter, Electronic ME-202/U

Voltmeter, Electronic ME-202/U (FSN 6625-050-8686) comprises the operable end item.

Page 5-11, appendix III. Delete appendix III.

By Order of the Secretary of the Army:

Official:

VERNE L BOWERS
Major General United States Army
The Adjutant General

CREIGHTON W. ABRAMS
General United States Army
Chief of Staff

Distribution:

To be distributed in accordance with DA Form 12-36, Direct/General Support avionics literature requirements for AN/AKT.18, AN/APS-94, AN/ASW-12 and AN/TKQ-1.

Technical Manual)
)
No. 11-6625-537-15)

HEADQUARTERS,
DEPARTMENT OF THE ARMY
Washington 25, D.C., 23 December 1962

Operator, Organizational, Field, and Depot Maintenance Manual
DIFFERENTIAL VOLTMETER M3-202/U

Section	Title	Page
I	INTRODUCTION AND SPECIFICATIONS	1-1
	1-1. General	1-1
	1-2. Specifications	1-1
II	OPERATING INSTRUCTIONS	2-1
	2-1. Controls and Terminals	2-1
	2-2. Preliminary Operation	2-1
	2-3. Measurement of DC Voltage	2-1
	2-4. Measurement of AC Voltage	2-2
	2-5. Measurement of Voltage Excursions About a Nominal Value	2-2
	2-6. Use as a Conventional VTVM	2-2
	2-7. Measurement of High Resistance	2-2
	2-8. Use of the 803 With a Recorder	2-2
	2-9. Notes on Measuring AC and DC Voltages	2-3
III	THEORY OF OPERATION	3-1
	3-1. General	3-1
	3-2. 500 V DC Reference Power Supply	3-1
	3-3. Kelvin-Varley Divider	3-1
	3-4. Vacuum Tube Voltmeter (VTVM)	3-1
	3-5. Chopper-Amplifier	3-2
	3-6. Converter	3-2
	3-7. Converter Power Supply	3-2
IV	MAINTENANCE	4-1
	4-1. General	4-1
	4-2. Preventive Maintenance	4-1
	4-3. Troubleshooting	4-1
	4-4. Calibration	4-4
V	LIST OF REPLACEABLE PARTS	5-1

CIRCUIT DIAGRAM

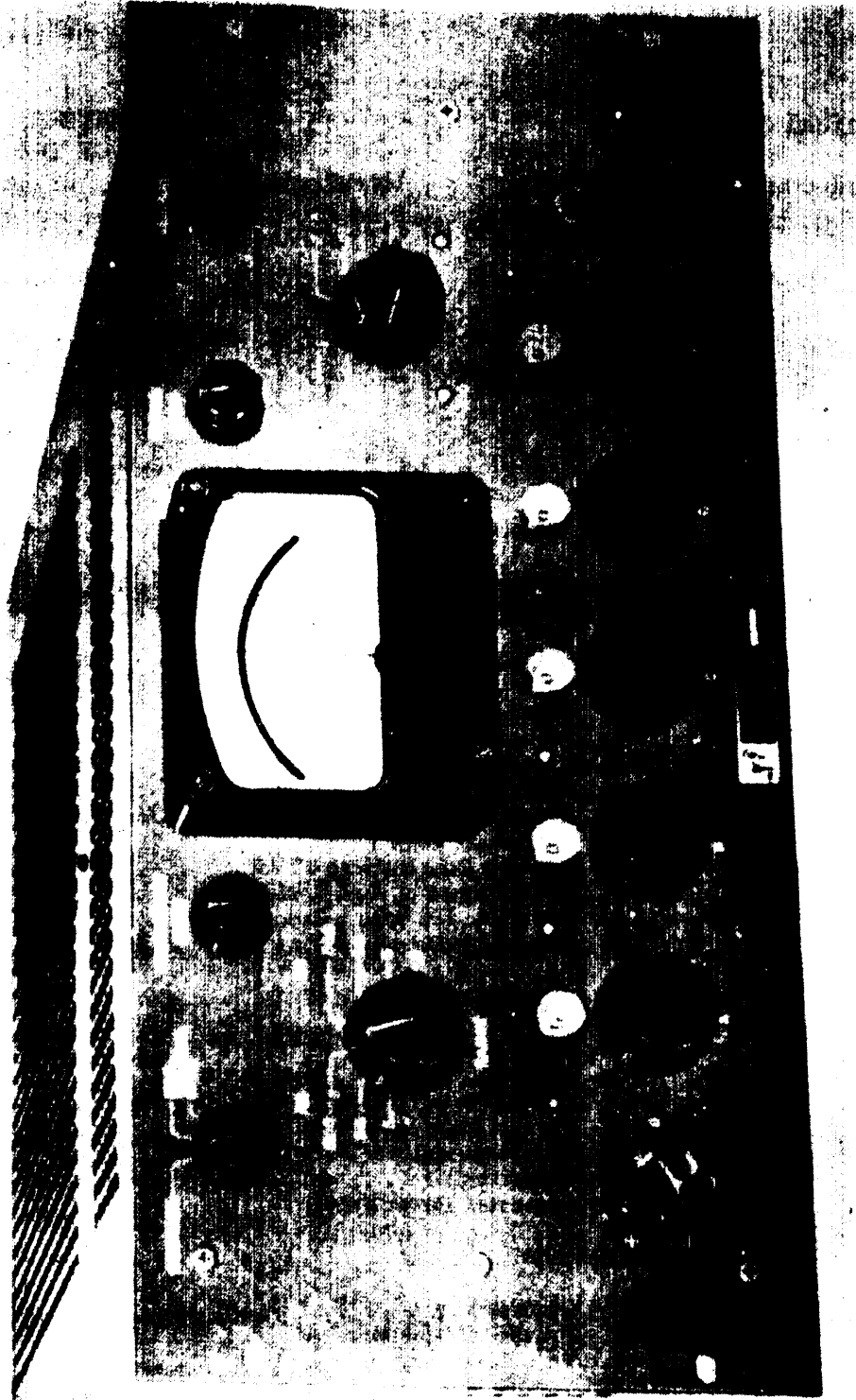

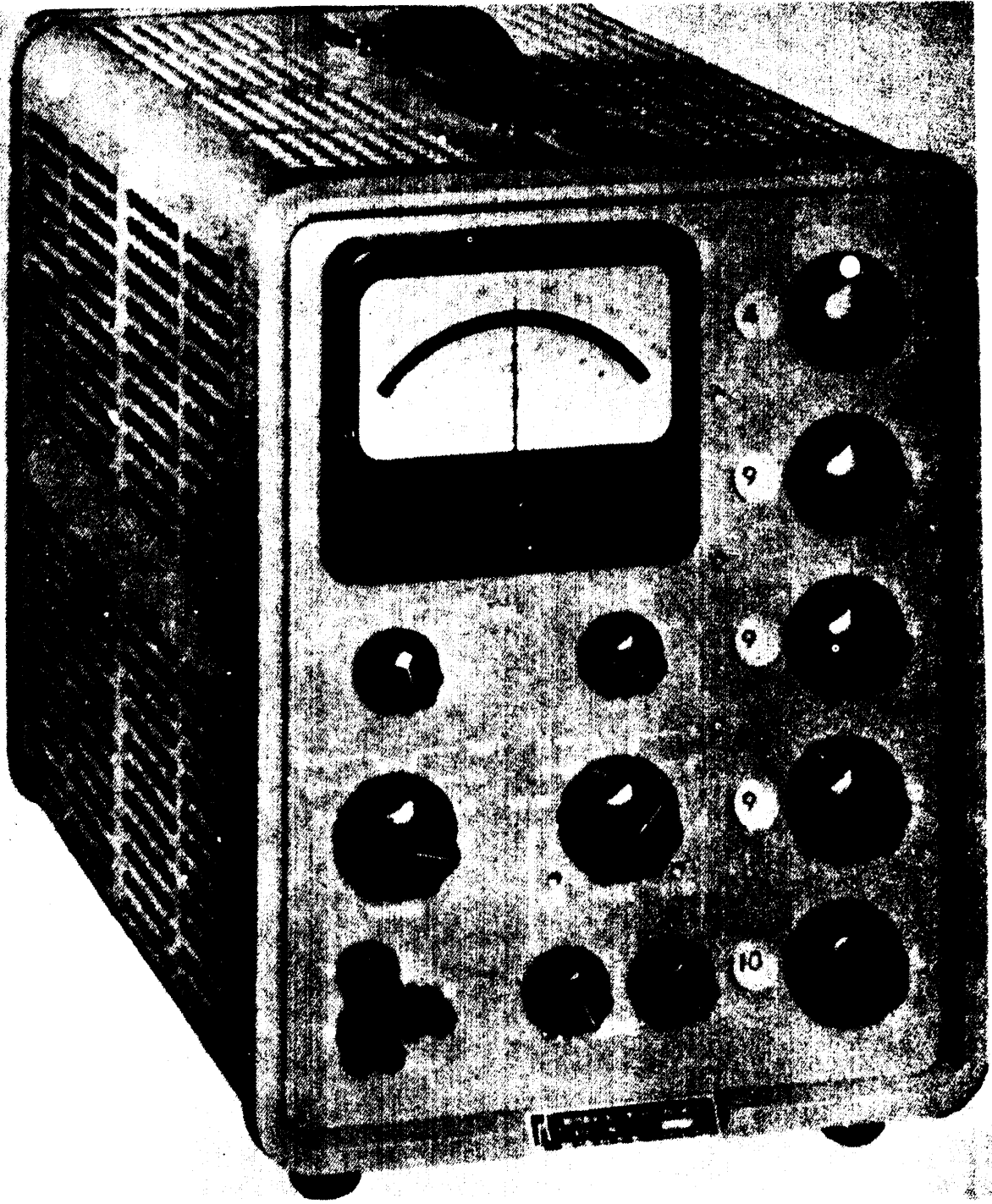

SECTION I

INTRODUCTION AND SPECIFICATIONS

1-1. GENERAL

a. The Model 803 AC-DC Differential Voltmeter has enjoyed wide acceptance in the field of voltage measurement. The high accuracy, portability, and compactness of the 803 make this instrument ideal for almost any application. Ease of operation and high reliability contribute to the outstanding performance which makes the 803 a Universally accepted instrument.

b. The heart of the 803 is a precision 500 V DC reference power supply. This 500 volts can be precisely divided into increments as small as 10 microvolt by means of five voltage dials. Unknown AC or DC voltages are matched against the precise internal voltage until no deflection occurs on the panel meter. The un-

known voltage is then simply read from the voltage dials. In the highest null sensitivity range, potential differences between unknown and reference voltage as small as 0.01 volts will cause full scale meter deflection.

c. At null, the 803 presents an infinite input impedance to the voltage under measurement, thereby completely eliminating circuit loading.

d. The instrument may also be used as a conventional VTVM or as a megohmmeter.

e. The Model 803 has been thoroughly checked and tested prior to shipment, and is ready for immediate use. Upon receipt, inspect carefully for any damage that may have occurred in transit.

1-2. SPECIFICATION

Following are the specifications of the Model 803.			Resolution:		
Input Voltage Range	Recommended Null Range	Input Impedance At Null	Input Voltage Range	Dial Resolution (Volts)	Meter Resolution (Volts)
DC:			DC:		
50-500	10-0-10 1-0-1	Infinite "	50-500	0.01	0.005
5-50	1-0-1 0.1-0-0.1	" "	5-50	0.001	0.0005
0.5-5	0.1-0-0.1 0.01-0-0.01	" "	0.5-5	0.0001	0.00005
0-0.5	0.1-0-0.1 0.01-0-0.01	" "	0-0.5	0.00001	0.00005
AC:			AC:		
50-500	10-0-10 1-0-1	1M, 25 uuf "	50-500	0.01	0.005
5-50	1-0-1 0.1-0-0.1	" "	5-50	0.001	0.0005
05-5	0.1-0-0.1 0.01-0-0.01	" "	0.05-5	0.0001	0.00005
			Accuracy:		
			DC: $\pm 0.05\%$ of input voltage from 0.1 to 500 V $\pm 0.1\%$ of input voltage or 0.00005 V, whichever is greater from 0 to 0.1 V.		
			AC: $\pm 0.2\%$ of input voltage from 0.5 to 500 V, reduced accuracy from 0.05 to 0.5 V.		

VACUUM TUBE VOLTMETER**Voltage Ranges:**

	<u>Input Voltage Range</u>	<u>Input Impedance</u>
DC:	±500	10M
	±50	10M
	±5	10M
	±0.5	10M
	±10*	10M
	±1 *	10M
	±0.1*	1M
	±0.01*	1M
AC:	0-500	1M, 25 uuf
	0-50	"
	0-5	"
	0-100*	"
	0-10*	"
	0-0.1*	"
	0-0.01*	"

*Using Null Ranges.

Accuracy: ±4%.

GENERAL SPECIFICATIONS**Reference Stability:**±0.01% maximum for 105 to 130 VAC line.
±0.01% per hour after 30 minute warmup.**AC to DC Converter Frequency Response:**
30 CPS to 10 KC.**Input Power:**

175 watts at 117/234 volts, 50/60 cycles.

Size:

Cabinet Model - 13" H x 9-3/4" W x 16" D.

Rack Model - 8-3/4" H x 19" W x 17-5/16" D.

Weight:

Cabinet Model - 30 pounds.

Rack Model - 38 pounds.

SECTION II

OPERATING INSTRUCTIONS

2-1. CONTROLS AND TERMINALS

The functions of the operating controls and terminals of the Model 803 are listed below:

a. The OFF-ON-CAL switch controls AC line power on cabinet model instruments. When placed in the CAL REF position, the chopper amplifier output may be calibrated, and in the CAL ADJ position, the internal 500 V DC reference voltage is calibrated. On rack model instruments, this switch is labelled OPERATE-CAL and line power is controlled by a toggle switch.

b. The RANGE switch selects AC voltage ranges of 500, 50, and 5 volts, or DC ranges of 500, 50, 5, and 0.5 volts.

c. The NULL switch is placed in the VTVM position to determine the approximate value of the unknown voltage prior to any differential measurements. The four null voltage ranges of 10, 1, 0.1, and 0.01 volts are used when differential measurements are made. For DC measurements, these ranges represent full scale differences between the unknown voltage and the portion of internal 500 V DC that is dialed up on the five voltage dials. For AC measurements, the null sensitivities are reduced on the 500 VAC and 50 VAC ranges as indicated by the X100 and X10 null range multiplier adjacent to the NULL switch. For example, on the 500 VAC range position, the X100 null multiplier lamp would light, and the maximum full scale voltage difference between internal reference and unknown would be 100 multiplied by the 0.01V null range, or 1 volt.

d. A, B, C, D, and E voltage dial settings provide an in-line readout of the amount of internal 500 V DC necessary to null (match) the unknown. Illuminated decimal points adjacent to the voltage dials change as the range of the instrument is changed.

e. ZERO controls are provided for calibrating the VTVM-10V-1V null ranges and the 0.1V-0.01V null ranges.

f. The positive input binding post is isolated from the chassis of the instrument, and the negative post is shunted to the chassis with a 1 UFD capacitor. Either post may be grounded or both may be "floated" from ground; however, since the instrument is equipped with 3-wire line cord with the third wire fastened to the chassis, the external circuit should be checked to avoid conflicts in grounding.

g. The ADJ CAL potentiometer controls calibration of the 500 V DC reference supply when the ON-OFF-CAL switch is in CAL ADJ position.

2-2. PRELIMINARY OPERATION

The following procedure prepares the 803 for operation.

a. Connect the power plug to an AC power source. The instrument is wired to operate on 117 VAC. Note on the schematic diagram that 220 VAC or 234 VAC operation is possible by rewiring the primary of the power transformer, and substituting a 1.5 Amp. line fuse.

b. Turn the RANGE switch to the 500 V DC position.

c. Turn the NULL switch to the VTVM position.

d. Turn all voltage dials to zero.

e. Place the instrument in operation by turning the OFF-ON-CAL control to ON. On rack models, turn the line power toggle switch to ON. The decimal lamp will light, indicating power is applied.

f. Allow a warmup period of at least ten minutes.

g. Adjust the VTVM-10V-1V ZERO control for zero meter deflection.

h. Turn the OFF-ON-CAL switch (OPERATE-CAL on rack models) to the CAL REF position and adjust the 0.1V-0.01V ZERO control for zero meter deflection.

i. Advance the switch against spring tension to the CAL ADJ position, and calibrate the internal 500 V DC reference supply by zeroing the meter with the ADJ CAL control.

j. Return the switch to the ON position (OPERATE position on rack models). The instrument is ready for use.

CAUTION

For personnel safety, the instrument is equipped with a 3-wire line cord so that the chassis will be grounded. Do not connect either binding post to the chassis ground post unless the circuit under test has been checked for conflicts in grounding.

2-3. MEASUREMENT OF DC VOLTAGE

a. After completing preliminary operation, connect the unknown voltage to the input binding posts with the range switch in the 500 V DC position. With the NULL switch in the VTVM position, the approximate value of the unknown will be indicated on the top meter scale. If the meter reads to the left, the polarity of the unknown voltage is opposite to the polarity of the instrument input, and the connections should be reversed.

b. Turn the RANGE switch to the lowest DC range which will give an on-scale reading and observe the approximate value of the unknown voltage.

c. Observe the position of the decimal light, and set the five voltage dials to the approximate voltage determined in step b. For example, if the approximate voltage is 3.5 volts, turn the A dial to 3, B dial to 5, and C, D, and E dials to zero.

d. Turn the NULL switch to the 10V position and adjust the voltage dials for zero meter deflection.

e. Turn the NULL switch to the 1V, 0.1V, and 0.01V positions, adjusting the voltage dials for zero meter deflection in each position.

f. Read the unknown voltage directly from the five voltage dials.

2-4. MEASUREMENT OF AC VOLTAGES

a. After completing preliminary operation, place the RANGE switch in the 500 VAC position.

b. Connect the unknown AC voltage to the positive and negative binding posts.

c. Proceed in the same manner as in measurement of DC voltage, step b and on.

2-5. MEASUREMENT OF VOLTAGE EXCURSIONS ABOUT A NOMINAL VALUE

a. After completing preliminary operation, set up the nominal voltage on the five voltage dials.

b. Turn the RANGE switch to the correct AC or DC position.

c. Connect the voltage under measurement to the input binding posts.

d. Turn the NULL switch to the position which allows the voltage excursions to remain on-scale. The NULL switch settings indicate full scale right and left meter deflections, except when the RANGE switch is set in the 500 VAC or 50 VAC positions. In these cases, the full scale excursions are equal to the NULL range setting multiplied by the X100 or X10 factor indicated by the NULL multiplier lamps.

2-6. USE AS A CONVENTIONAL VTVM

If it is desired to use the instrument as a VTVM only, the NULL ranges may be converted to VTVM ranges by setting the voltage dials to zero. Proceed as follows:

a. Perform preliminary operation procedures stated in paragraph 2-2.

b. Consult figure 2-1 and select full scale voltage deflection desired. If the approximate value of the voltage to be measured is unknown, select the 500V range initially.

c. Set RANGE switch, NULL switch, and voltage dials as indicated for the range selected.

d. Connect the voltage to be measured to the input binding posts. Deflection to the right indicates same polarity as binding posts.

e. Read voltage from upper or lower scale as listed in figure 2-2.

2-7. MEASUREMENT OF HIGH RESISTANCES

One of the important features of the Model 803 is the ability to be used as a megohmmeter for high resistance measurements from 1 to 500, 000 megohms. In this application, connect the minus input terminal to the chassis ground post and use short isolated leads to the unknown resistance to prevent measuring leakage resistance of the leads. Proceed as follows:

a. Perform the preliminary operation procedure. For resistances over a range from 1 to 500 megohms, set RANGE switch to 500 V DC, NULL switch to 10V, and adjust voltage dials for full scale deflection with the unknown resistance connected to the input terminals. Subtract 10.00 from the dial reading for the resistance of the unknown in megohms.

b. For resistances over a range from 500 to 5000 megohms, set RANGE switch to 500 V DC, NULL switch to 1V, and adjust voltage dials for full scale meter deflection. Subtract 1.00 from the dial reading and multiply the result by 10 for the resistance of the unknown in megohms.

c. Between 5000 and 500,000 megohms, the resistance is calculated from the following formula:

$$R_x = 10 \left(\frac{E}{E_m} - 1 \right), \text{ where}$$

R_x = unknown resistance in megohms

E = voltage indicated by voltage dials

E_m = meter reading from 0 to 1V on the bottom meter scale (1V null range)

10 = megohms input resistance of the VTVM circuit in the 1V null range

Set the RANGE switch to 500 V DC, NULL switch to the 1V range, and adjust the voltage dials for a convenient meter deflection. Substitute the meter reading in volts and the voltage dial setting in volts into the equation to obtain unknown resistance.

2-8. USE OF THEM WITH A RECORDER

Recorder output binding posts and level control are provided on the rear of the 803 for monitoring the excursions of an unknown voltage from the voltage indicated by the dial settings. The leakage resistance between the recorder and ground must be greater than 500, 000 megohms or the accuracy of the 803 will be impaired. The John Fluke Model A-70 Potentiometric Recorder (manufactured by the Texas Instrument Co.) is recommended for this application. Set up the recorder as follows:

a. Connect recorder input terminals to 803 output terminals with teflon leads.

CAUTION

Do not ground either of the recorder output terminals to the chassis of the 803. It is possible that the 1/200 ampere fuse at the output of the Kelvin-Varley divider will be blown.

b. After connecting the recorder, perform preliminary operation.

c. Check for excessive leakage by connecting a standard cell to the 803 and measuring the EMF. Then alternately connect and disconnect the recorder leads at the rear of the 803. More than 1/4 small scale division deflection of the 803 indicates excessive leakage has been introduced by the recorder, and 803 accuracy will be impaired. If less than 1/4 division, make another check by setting the RANGE switch to 500 V DC, NULL switch to 1V, and all voltage dials to zero. Zero the instrument with the VTVM-10V-1V control, then set the voltage dials to 400.00. A properly operating 803 will deflect less than 1/4 small scale division with the recorder leads disconnected. If more than 1/4 division deflection occurs with leads connected, accuracy will be impaired.

- d. When leakage checks have been completed, short the input terminals of the 803.
- e. Turn the RANGE switch to the 50V position, NULL switch to the 10V position, and dial up 10,000 volts. The meter will deflect full scale, giving a maximum output at the recorder terminals of 15 millivolts.
- f. Turn the GAIN ADJ potentiometer adjacent to the recorder terminals for the recorder deflection that is desired to correspond to full-scale 803 deflection.
- g. Remove the short from the 803 input terminals. The 803-Recorder combination is ready for use. Proceed as instructed under paragraph 2-5.

2-9. NOTES ON MEASURING AC AND DC VOLTAGES

- a. When selecting the AC or DC range of operation, always use the lowest range that will give an on-scale reading with the NULL switch in the VTVM position. This will assure that the maximum number of Kelvin-Varley voltage dials will be used, providing the best accuracy. For example, when measuring 3.52 volts, set the RANGE switch to the 5 V DC position and use all 5 voltage dials, rather than the 500 V DC position, where only three dials could be used.
- b. Any NULL range may be used at any input voltage. However, it is recommended that the 10V and 1V null ranges be used for voltages higher than 50 volts; 10V, 1V, and 0.1V null ranges are recommended between 5 and 50 volts. A badly fluctuating line voltage or an unstable input voltage may cause meter rattle or erratic movements if higher null sensitivities are used on these voltage ranges.
- c. AC components do not normally effect DC measurements in the 10V and 1V null ranges. In the 0.1V and 0.01V null ranges, the filter network at the input of the chopper-amplifier will attenuate the AC component,

This filter has an attenuation ratio of 330 to 1 at 60 cycles. For example, a one-half volt, 60 cycle AC component will be reduced to slightly over one millivolt. If large AC components are present on the DC to be measured, and the 0.1V and 0.01V (chopper-amplifier) null ranges must be used, additional filtering is required. If the AC is of a single frequency, a twin-T filter is effective and has the advantage of low total series resistance. If the AC is of variable frequency, an ordinary low-pass filter may be used. In either case, the capacitors used should be high quality units of high leakage resistance.

- d. When making measurements of negative DC voltage, the positive binding post should not be connected to the chassis binding post. This would place C101, a 1 MFD capacitor, directly across the input. Since the chassis binding post is connected to earth ground through the 3-wire line cord, this may happen inadvertently if the source of the voltage being measured has the positive side grounded. When C101 is directly across the voltage being measured, a small 60 cycle signal (50 millivolts or less) appears across this capacitor due to slightly unbalanced capacitances between the power transformer high voltage windings and the core. This may affect the true DC reading, or the source under measurement, or both.
- e. When making AC measurements, the presence of harmonics may have an effect on accuracy. Figure 2-2 indicates how accuracy will be affected by various harmonics for different percentages of distortion.

Full-Scale Deflection	Range Switch	Null Switch	Multiplier	Voltage Dials	Meter Scale
DC					
500-0-500	500 V DC	VTVM	-	No effect	Upper
50-0-50	50 V DC	VTVM	-	No effect	Upper
10-0-10	No effect	10	-	All zero	Lower
5-0-5	5 V DC	VTVM	-	No effect	Upper
1-0-1	No effect	1	-	All zero	Lower
0.5-0-0.5	0.5 V DC	VTVM	-	No effect	Upper
0.1-0-0.1	No effect	0.1	-	All zero	Lower
0.01-0-0.01	No effect	0.01	-	All zero	Lower
AC					
500-0-500	500 VAC	VTVM	-	No effect	Upper
100-0-100	500 VAC	1	X100	All zero	Lower
50-0-50	50 VAC	VTVM	-	No effect	Upper
10-0-10	50 VAC	1	X10	All zero	Lower
5-0-5	5 VAC	VTVM	-	No effect	Upper
1-0-1	5 VAC	1	-	All zero	Lower
0.1-0-0.1	5 VAC	0.1	-	All zero	Lower
0.01-0-0.01	5 VAC	0.01	-	All zero	Lower

Figure 2-1. VTVM RANGES

HARMONIC	% DISTORTION	%ERROR* MAXIMUM POSITIVE	MAXIMUM NEGATIVE
Any even harmonic	0.1	0.000	
	0.5	0.0001	
	1.0	0.005	
	2.0	0.020	
Third harmonic	0.1	0.033	0.033
	0.5	0.168	0.167
	1.0	0.338	0.328
	2.0	0.687	0.667
Fifth harmonic	0.1	0.020	0.020
	0.5	0.101	0.099
	1.0	0.205	0.195
	2.0	0.420	0.380

*Error depends upon phase relationship between harmonic and fundamental for odd harmonics, i. e. error can be any value between maximum positive and maximum negative, including zero.

Figure 2-2. HARMONIC DISTORTION

SECTION III

THEORY OF OPERATION

3-1. GENERAL

a. A functional schematic of the Model 803 is shown following Section V. The functional method of circuit representation is designed to aid the reader in discussions of circuit theory and troubleshooting.

b. As seen on the schematic, the principle circuit divisions are: 500 V DC reference power supply; Kelvin-Varley divider; vacuum tube voltmeter (VTVM); chopper-amplifier; converter, and converter power supply.

3-2. 500 V DC REFERENCE POWER SUPPLY

a. When the 803 is used in the differential mode for voltage measurements, an internal precision DC voltage is nulled or matched against the unknown voltage. An extremely accurate reference voltage is therefore required. This voltage is developed by the 500 V DC reference supply, V1 through V8.

b. V1, (full wave rectifier) and the associated filter network, supply raw DC voltage at approximately 1000 volts to the pre-regulator tube V2. Any change in the output of the pre-regulator is felt at the grid of V3, the cathode of which is clamped by voltage regulator V4. The plate potential of V3, which is coupled to the grid of V2, will change to correct the output of the pre-regulator, which should be approximately 650 volts to V5A, the main regulator.

c. The grid of the main regulator is driven by V5B, which in turn is driven by differential amplifier V8. Changes in the output of the main regulator are felt at pin 2 (grid) of V8. Since the opposite grid (pin 7) is clamped by voltage regulators V6 and V7, and the cathodes are tied together, V8 drives the grid and cathode of V5B in opposite directions to change the grid potential of V5A, correcting the main regulator output. The output is maintained at 500 V DC $\pm 0.01\%$.

d. In the 500 V DC position, the RANGE switch (S102E) passes this 500 volts directly to the Kelvin-Varley divider. In the 50 V DC, 5 V DC, and 0.5 V DC positions, range resistors controlled by S102F divide the reference voltage to 50 V DC, 5 V DC, and 0.5 V DC respectively. In all AC positions of the RANGE switch, only 5 volts of the reference supply is used, due to the fact that the maximum output of the AC to DC converter is 5 volts. This is explained in the discussion of the converter.

3-3. KELVIN-VARLEY DIVIDER

a. Each one of the four precision voltages available from the reference supply must be made adjustable through a precision divider string so that unknown voltages may be nulled or matched exactly. The five Kelvin-Varley decade resistor strings accomplish this function.

b. Note that each string, with the exception of the first, parallels two resistors of the string that precedes it. Between the two wipers of S104 (voltage dial "A") then, there is a total resistance of 40K and a total voltage of 100 V DC, with the RANGE switch in the 500 V DC position. Across the wipers of S105, S106, and S107, there are 10 V DC, 1 V DC, and 0.1 V DC respectively. S108 (dial "E") picks increments of 0.01 V DC from the last decade. These voltages are reduced by a factor of 10 for each lower range voltage.

c. All resistors of each decade are matched and all decades are matched for each instrument, providing an over-all divider accuracy of 0.005%.

d. With the NULL switch in any null range, the output of the Kelvin-Varley divider appears at the grid of one-half of the VTVM differential amplifier, V204B. A 1/200 ampere (5 milliamperes) fuse protects this output.

3-4. VACUUM TUBE VOLTMETER (VTVM)

a. When operating in the differential mode, Kelvin-Varley output voltage appears on the grid of V204B, one-half of differential amplifier V204. The unknown voltage appears on the grid of V204A, the other half of the differential amplifier. Any difference between these potentials will be indicated by the meter which is coupled between the cathodes of V204. When the Kelvin-Varley output voltage exactly matches the unknown, the meter will read zero and no current will be drawn from the source being measured, because the same potential exists on both sides of the input resistances R105 through R109.

b. An 0.5 volt difference between potentials on the grids of the differential amplifier will drive the meter to full-scale deflection. As seen on the schematic, the voltage division across R105, R106, and R107 will provide 0.5 volt difference to the differential amplifier grids in the 10V null range if the actual difference between unknown and Kelvin-Varley voltage is 10 volts; in the 1V null range, a different division of potential will pro-

ide 0.5 volt to V204 for a 1V difference between unknown voltage and reference voltage.

c. In the 0.1V and 0.01V null ranges, the chopper-amplifier is used to provide the 0.5 volts necessary for full-scale deflection of voltage differences as small as 0.1 and 0.01 volt.

d. When used as a conventional VTVM, the grid of V204B is connected to the 0 volt buss, or negative binding post. With the range switch in the 0.5 V DC position, the 0 to 0.5 V DC unknown voltage appears directly on the grid of V204A, and will indicate the approximate value of the unknown. Input divider resistors R110 through R116 maintain the 0 to 0.5 grid voltage range for all instrument voltage ranges. The input resistance of the instrument in the VTVM position is seen to be 10 megohms, the sum of R110, R112, R114, and R116.

c. The chopper-amplifier is used during calibration of the 500 V DC reference supply. With the OFF-ON-CAL switch in the CAL ADJ position, a fixed percentage of the reference supply is compared to the precise EMF of the internal standard cell. Any difference in potential is fed to the chopper-amplifier and VTVM so that the reference supply may be adjusted by means of R119 (ADJ CAL potentiometer) to 500 V DC $\pm 0.01\%$.

3-5. CHOPPER-AMPLIFIER

a. Since the grid drive to V204 must be 0.5 volts for full-scale meter deflection, a chopper amplifier is employed to boost the DC potential difference between the unknown and internal reference, when operating in the 0.1V and 0.01V null ranges.

b. The chopper-amplifier is a fixed-gain device consisting of V205 and V206. A 60 cycle chopper modulates any DC level appearing at the input. The resulting square-wave is amplified and demodulated by another chopper contact. The resulting DC gain is approximately 50. Therefore, for 0.01 volts maximum input, the output will be 0.5 volts, enough for full-scale deflection of the VTVhf. In the 0.1V null range, the input to the chopper amplifier is still 0.01 volt for full-scale deflection, because of the R108-R109 divider.

3-6. CONVERTER

a. All AC measurements are made by first converting the AC input to a DC voltage. The converter provides a maximum DC output of 5 volts for a maximum AC input of 5V RMS. In the 5 VAC position, then, range switch sections S102A and S102B couple the converter amplifier input directly to the binding posts. In the 50 VAC and 500 VAC positions, input attenuators reduce the unknown AC to provide a maximum of 5 VAC input to the first converter amplifier.

b. Three stages of amplification are employed in the converter, terminated at cathode follower V404. From the cathode, full-wave negative feedback returns to the grid of the first amplifier. Half-wave rectification and filtering of the cathode follower output result in a DC voltage that is proportional to the RMS value of the AC input up to 5 V DC.

c. The over-all frequency response of the converter is essentially flat from 30 CPS to 10 KC.

3-7. CONVERTER POWER SUPPLY

a. Plate and DC filament voltages for the converter are developed in the converter power supply. V301 and C301 provide unregulated DC to the plate of V302, the series regulator for the 250 V DC plate voltage. Differential amplifiers V303 and V304 correct the grid potential of V302 as necessary to maintain the output at 250 V DC. V305 is the series regulator for the 140 V DC converter plate supply, and is driven by differential amplifier V306 to maintain a constant output.

b. The DC filament voltage is developed in a transistorized regulator circuit consisting of TR1, TR301, and TR302. The base of TR302 is maintained at a fixed negative potential by V309, a voltage regulator. Since the filament voltage is negative, a decrease in the absolute value of this voltage will cause the emitter and collector of TR302 to become more positive. This change is amplified by TR301, and the base of TR1 is driven in a negative direction, causing more filament current to be drawn through TR1. This will return the filament voltage to its proper negative value.

c. The same half-wave power supply (CR9 and C310) that develops a negative voltage for base bias of TR302 is used to light the decimal and null multiplier lamps,

SECTION IV

MAINTENANCE

4-1. GENERAL

Maintenance of the Model 803 is seldom required. Preventive maintenance consists only of keeping the interior and exterior of the instrument clean as discussed in paragraph 4-2. A troubleshooting chart, component location diagram, tube voltage chart, and a discussion of troubleshooting is provided in paragraph 4-3. Paragraph 4-4 outlines the equipment and procedures necessary to calibrate the 803.

4-2. PREVENTIVE MAINTENANCE

a. The 803 is extremely sensitive to the slightest amount of electrical leakage from the VTVM channel to the 0 volt buss, particularly from the input grid (pin 2) of V204. This leakage becomes evident when the voltage dials are set to a high voltage with the NULL switch in any null range, and no input at the binding posts. Less than 1/4 small scale division of leakage should be indicated on the meter. Accumulations of dust and foreign matter will cause internal leakage, and should be removed as often as necessary, depending on environmental operating conditions. Most accumulations can be removed by blowing the instrument out with low pressure, clean, dry air. In older configurations of the 803, two plexiglass strips were used to insulate the VTVM printed circuit board from the metal chassis. Pay particular attention to these strips when cleaning.

b. After blowing the instrument out, clean the NULL and RANGE switches with a brush dipped in Metriclene Solvent M-4, manufactured by the John B. Moore Corp., Nutley, New Jersey. In older instruments, also clean the above mentioned plexiglass strips with this solvent. After cleaning the switches, recoat the ceramic surfaces of the switches with a 10% solution of Dow Corning 200 Fluid (100 viscosity grade) in Metriclene. This prevents moisture from collecting across the ceramic surfaces.

c. When cleaning the binding post, insulators and front panel, do not use Metriclene Solvent. Use only denatured alcohol and a clean cloth, as the insulator material is slightly soluble in Metriclene.

d. If necessary, lubricate the detent mechanisms and shaft bearings of the switches sparingly. In no case should lubricant be applied to switch wafers, as leakage will result.

4-3. TROUBLESHOOTING

a. Failure of the 803 to operate properly is usually traced to failure or aging of one or more of the tubes to the point where they can no longer operate satisfactorily in the circuit. The schematic diagram and the circuit description in Section III should be reviewed before attempting to troubleshoot the instrument. The schematic is laid out in a functional manner with left-to-right signal flow in general.

b. When it becomes necessary to replace one or more tubes, it must be realized that certain tubes in the 803 perform critical functions, and replacements must be selected. Such tubes are the following:

(1) V8 is a high-mu dual triode, type 12AX7, used as a differential amplifier. Some replacement tubes may have poor balance between halves causing poor regulation against line voltage in the 500 V DC reference supply. Check for this by allowing 5 minutes for tube to heat and then varying line voltage from 105 to 130 volts and checking reference supply output voltage with another Model 803 or 801. The 500 volts must not change by more than 50 millivolts (0.01%) over this range of line voltage. If regulation exceeds this figure, discard tube in favor of another. Such discards may work very well for V206 in the chopper amplifier since it is an AC coupled amplifier not dependent upon the DC tube characteristics for proper performance.

(2) V204 is a medium-mu dual triode used in a cathode follower type VTVM circuit. The two requirements of V204 for satisfactory performance are good balance between halves and low grid current. These can be checked by setting RANGE switch to 500 V DC, NULL switch to 1V and all five voltage knobs to zero. Allow a few minutes for tube heating and then check for ability to zero meter. At zero, the VTVM-10V-1V zero knob pointer should lie within $\pm 90^\circ$ of vertical. If outside these limits remove tube and try another. If okay, vary line voltage from 105 to 130 VAC and check stability of meter zero. Meter should not offset more than $\pm 4\%$ (2 small scale divisions). If excessive offset exists, check the heater voltage to determine whether the 9-7 ballast tube is functioning properly. Heater voltage at 117 VAC line should measure between 5.5 and 6.5 volts and should change less than 0.5 volt for a line voltage change from 105 to 130 volts. If outside these limits,

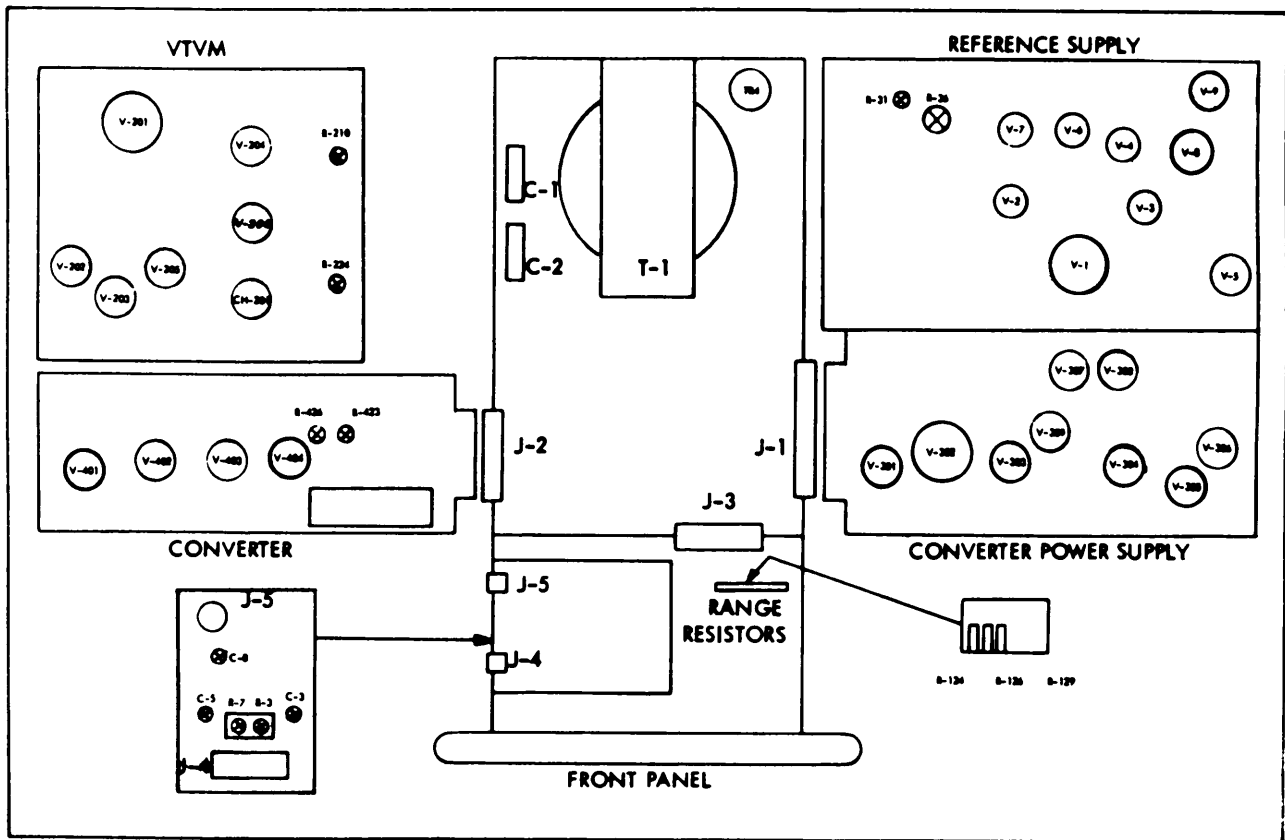

Figure 4-1. COMPONENT LOCATION

replace the 9-7. If the ballast tube is functioning properly but the meter offset exceeds 2 small scale divisions for a 25 volt change in line voltage, discard V204 in favor of another tube with better balance. To check for excessive grid current in V204, set RANGE switch to 500 V DC, NULL switch to 1V, the five voltage knobs to zero, and line voltage to 117 volts. Zero meter, then short the input binding posts. Meter offset must not exceed 1/4 of one small scale division; if it does, replace V204.

(3) V401 is a sharp cutoff pentode used as the first stage of the converter three stage feedback amplifier. It is important that this tube not be microphonics to prevent meter rattle when measuring AC voltage.

(4) Replacement of V206, the 12AX7 chopper amplifier tube should be made with one which is not microphonics. The Westinghouse type 12DF7 is a low microphonic version of the 12AX7 and may be used if desired. A microphonic or otherwise noisy tube may cause meter rattle in the 0.01 and 0.1 volt null ranges. Another possible source of meter rattle in these ranges is a defective 0B2 (V203).

c. Figure 4-1 is a component location diagram showing the location of all tubes, Figure 4-2 gives the pin voltage of all tubes as an aid to troubleshooting. Figure 4-3 is a troubleshooting chart that documents the cause and remedies for the most common symptoms of instrument malfunction.

d. The standard cell of the 803 deserves special consideration if it is suspected of being faulty:

(1) The standard cell used in the Model 803 is an Eppley type MIN 1. This is a miniature low hysteresis

unit which has excellent long term stability and negligible temperature hysteresis. (Hysteresis is a temporary increase in EMF immediately following a decrease in temperature; this effect should not be confused with temperature coefficient). Under normal conditions this cell should last from 8 to 15 years. In rare instances, failure has occurred in less than 2 years. End of life is usually marked by an increase in temperature hysteresis effect. That is, reading errors in excess of 0.05% will result when the same voltage is read with the 803 hot and cold. Should replacement of the cell become necessary for any reason, the instrument must be recalibrated (basic 500 volt range only), since the EMF of different cells may be different by as much as 0.05% and each instrument is calibrated to its own particular standard cell. Refer to the recalibration instructions in this case.

(2) Failure of the standard cell may occur if subjected to below freezing temperature. The electrolyte will freeze at -17°C and operation below 0°C is definitely not recommended. The life of the cell also will be greater if the 803 is not operated at elevated temperatures. The 8 to 15 year figure holds for operation of the instrument in normal room temperature.

(3) The EMF of the standard cell will change if the cell has been inverted, or if the cell has been inadvertently short-circuited. If the EMF has changed, the 803 will naturally be out of calibration on all ranges. In either case, the cell will return to its original EMF. If the cell were inverted or shorted for only a few seconds, the 803 should be able to measure voltages within specifications after several hours recovery time.

TUBE VOLTAGE CHART*									
Symbol & Type	Pin 1	Pin 2	Pin 3	Pin 4	Pin 5	Pin 6	Pin 7	Pin 8	Pin 9
V1, 5Y3GT	0	1000	0	a-c 800	0	a-c 800	0	1000	-
V2, 6AQ5A	620	660	660	660	1000	1000	630	-	-
V3, 6AU6	146	150	150	150	630	280	150	-	-
V4, OA2	150	0	0	0	150	0	0	-	-
V5, 12AU7	660	420	500	500	500	500	400	420	500
V6, OG3	170	85	170	0	170	22	85	-	-
V7, OG3	85	0	85	0	85	3.6	0	-	-
V8, 12AX7	420	170	170	170	170	410	170	170	170
V9, 9-7	0	170	0	0	0	0	170	-	-
V201, 9-7	108	0	0	0	0	108	0	-	--
V202, OA2	150	0	0	0	150	0	0	-	-
V203, OB2	108	0	0	0	108	0	0	0	-
V204, 12AU7	108	0	6	a-c 6.3	a-c 6.3	108	0	6	a-c 6.3
V205, 6C4	101	0	a-c 6.3	a-c 6.3	100	0	6.3	-	-
V206, 12AX7	85	-.71	.15	a-c 6.3	a-c 6.3	82	-1.13	0	a-c 6.3
V301, 6X4	a-c 380	a-c 380	260	260	260	a-c 380	460	-	-
V302, 5881	260	260	460	460	245	255	255	255	-
V303, 6AW8	180	175	260	a-c 6.3	a-c 6.3	180	175	260	245
V304, 12AX7	175	86	87	0	0	175	85	87	0
V305, 6AQ5A	130	140	0	0	260	260	143	-	-
V306, 6AW8	44	42	140	a-c 6.3	a-c 6.3	44	38.5	140	143
V307, OG3	85	0	85	0	85	7.5	0	-	-
V308, OA2	0	-150	0	-150	0	0	-150	-	-
V309, OG3	0	-85	0	-85	0	-6.2	-85	-	-
V401, 6DK6	0	1.75	0	-6.4	106	134	0	-	-
V402, 6DK6	0	1.65	0	-6.4	98	134	0	-	-
V403, 6DK6	0	2.5	0	-6.4	150	145	0	-	-
V404, 12AU7	260	150	150	-6.8	-6.8	260	140	142	0

*This chart is to be used under the following conditions: (a) range switch set to 500 V DC; (b) null switch set to VTVM; (c) line voltage at 117 V, 60 cycles; (d) all measurements made from negative binding post to specified terminal; (e) all measurements made with a VTVM; (f) all voltage dials set to zero; and (g) zero adjust pots counter-clockwise..

Figure 4-2. TUBE VOLTAGE CHART

e. The mercury cell, B201, is used as a source of grid bias voltage in the chopper-amplifier. This cell has an expected life in the instrument from 2 to 4 years. Replacement should be made when the cell voltage falls below 1.2 volts. A defective cell usually is evidenced by inability to zero the 0.1V-0.01V null ranges.

f. The chopper, G1, normally has a life approaching that of the standard cell. However, if the contacts are overloaded often or for extended periods of time, the contacts become corroded and the chopper-amplifier will not work properly. Poor chopper operation is indicated by erratic needle movements in the 0.1V and 0.01V null ranges, or reduced sensitivity in these ranges.

4-4. CALIBRATION

a. GENERAL. Calibration of the Model 803 should be accomplished in a draft-free area with an ambient temperature of 72°F \pm 5°F for maximum accuracy under typical laboratory operating conditions. DC calibration must be performed prior to AC calibration and consists of: setting the gain of the VTVM circuit; setting chopper-amplifier gain; calibrating the 500 V DC reference supply; and calibrating the 50, 5, and 0.5 V DC range dividers of the reference supply. AC calibration consists of calibrating the converter on the basic 5 VAC range, and calibrating the converter input attenuator in the 50 VAC and 500 VAC ranges. See figure 4-1 for adjustment locations.

b. DC CALIBRATION (See figure 4-4).

(1) Place instrument in operation and allow at least one hour warm-up time.

(2) Set up the necessary equipment to provide DC voltages of 500, 50, 5, and 0.5 V DC with an accuracy of at least 0.01%. The recommended equipment and method of connection is shown in figure 4-4. The required voltages are obtained by: setting the standard cell voltage on the ESI divider; putting 500 V DC into the divider from a Model 301C or 301E power supply; and zeroing the galvanometers when the push button switches are pressed by means of the vernier control on the power supply (ESI divider set at 500V). 500, 50, 5, and 0.5 V DC \pm 0.01% are available at the output posts of the divider by merely changing positions of the right hand knob.

(3) Place the RANGE switch in the 0.5V DC position, and the NULL switch to VTVM.

(4) Zero the meter with the VTVM-10V-1V zero control.

(5) Apply 0.5 V DC to the instrument, and adjust R210 for full scale meter deflection. This calibrates the VTVM circuit.

(6) Remove the 0.5 V DC input.

(7) Set all voltage dials to zero and place a 39K resistor across the input terminals.

(8) Set RANGE switch to 5 V DC, and NULL switch to the 0.01V null range.

(9) Zero the meter with the 0.1V-0.01V zero control.

(10) Turn C voltage dial to 1.

(11) Using an insulated screwdriver, adjust R224 for exactly one small scale division less than left full scale meter deflection. This calibrates the chopper-amplifier gain.

(12) Begin calibration of the 500 V DC reference supply by setting voltage dials to 499.910, RANGE switch 500 V-DC, and NULL switch to 1V range.

(13) Adjust VTVM-10V-1V control for zero meter deflection.

(14) Apply 500 V DC \pm 0.01% to instrument.

(15) Turn ADJ CAL potentiometer for zero meter deflection. If knob is not centered approximately, turn knob to center position, remove instrument from case, and adjust R31 for zero meter deflection.

(16) Turn OFF-ON-CAL switch (OPERATE-CAL on rack models) to the CAL REF position.

(17) Adjust 0.1V-0.01V zero control for zero meter deflection.

(18) Advance OFF-ON-CAL switch to the CAL ADJ position, and adjust R36 for zero meter deflection.

(19) Return OFF-ON-CAL switch to the ON position. Meter should still read zero. If not, repeat from step (12).

(20) Remove 500 V DC input.

(21) Place RANGE switch in 50 V DC position, NULL switch to 0.1V range, and leave voltage dials at 49.9910.

(22) Adjust 0.1V-0.01V control for zero meter deflection.

(23) Apply 50 V DC \pm 0.01% to instrument.

(24) Adjust 50 V DC range potentiometer R124 for zero meter deflection.

(25) Remove 50 V DC input, set RANGE switch to 5 V-DC, NULL switch to the 0.01V range, and leave voltage dials at 4.99910.

(26) Apply 5 V DC \pm 0.01% to instrument.

(27) Adjust 5 V DC range potentiometer R126 for zero meter deflection.

(28) Remove 5 V DC input, set RANGE switch to 0.5 V DC, leave NULL switch at 0.01V range, and voltage dials at .499910.

(29) Apply 0.5 V DC \pm 0.01% to instrument.

(30) Adjust 0.5 V DC range potentiometer R129 for zero meter deflection.

(31) Remove 0.5 V DC input. This completes DC calibration.

c. AC CALIBRATION. Calibration of the Model 803 has been accomplished at frequencies of 400 cycles and 10 kilocycles since serial number 2625. Prior to that instrument, calibration frequencies were 400 cycles and 5 kilocycles. The AC calibration equipment recommended herein is capable of producing calibrating voltages of 500, 50, and 5 VAC \pm 0.05% at frequencies of 400 cycles and 10 kilocycles, with less than 0.1% total harmonic distortion. Instruments with lower serial numbers than 2625 should be calibrated at 5 KC with this same equipment, with the exception of the Elin oscillator. Elin Model VC-555 will provide 5 KC.

(1) After DC calibration has been completed, set up the equipment as shown in figure 4-5. The required AC voltages are obtained by: Setting up a precise DC voltage with the power supply-differential voltmeter combination that has the same value as the AC voltage required; the precise DC voltage is then compared with the oscillator AC voltage at the Model 540A transfer device, and the oscillator output is adjusted so that the RMS value of the oscillator output is exactly the same as the precise DC voltage.

(2) Calibrate the basic 5 VAC range by setting the voltage dials to zero, RANGE switch to 5 V DC and NULL switch to 0.01V range.

(3) Mjust 0.1V-0.01V zero control for zero meter deflection.

(4) Place NULL switch to VTVM and RANGE switch to 5 VAC.

SYMPTOM	PROBABLE CAUSE	REMEDY
<p>Drift of the 500 V DC reference supply evidenced by the continual need for resetting the 500 V DC with the ADJ CAL potentiometer</p>	<p>V6, V7, or V8 defective.</p> <p>One of the sampling string resistors R30, R32, R33, R34, and R35) is changing value rapidly as the instrument warms up.</p> <p>Drifting standard cell EMF possibly caused by previous shorting or inverting of the cell.</p>	<p>Check by replacement V6, V7, and V8.</p> <p>Locate faulty resistor by heating slightly with a soldering iron held near the resistor while observing the 500 V DC calibration.</p> <p>Allow time for the standard cell to stabilize. Several hours should be sufficient.</p>
<p>Cannot calibrate 500 V DC reference supply. Meter cannot be brought to zero before ADJ CAL knob reaches limit.</p>	<p>Excessive aging of V6 or V7.</p> <p>Out of calibration.</p> <p>One or more resistors in 500 V DC sampling string has shifted in value.</p> <p>Standard cell EMF has shifted.</p>	<p>Check by replacement V6 and V7.</p> <p>Recalibrate per paragraph 4-4.</p> <p>Recalibrate per paragraph 4-4 and observe stability for 48 hours. If 500 V DC reference supply remains stable, replacement of resistor is unnecessary.</p> <p>Recalibrate instrument and observe stability of reference supply. Replacement of the standard cell may be necessary.</p>
<p>Measurements are out of tolerance on one DC range other than the 500 V DC range.</p>	<p>A range resistor in the reference supply output is out of tolerance.</p>	<p>If the trouble occurs in the 50 V DC range, R123 has shifted; in the 5 V DC range, R125 or R127 has shifted; in 0.5 V DC range, R128 or R130 has shifted. It may be possible to correct by recalibration. If not, replace faulty resistor.</p>
<p>Measurements are out of tolerance on all DC ranges other than the 500 V DC range.</p>	<p>R120 or R121 has shifted in value.</p>	<p>It may be possible to correct all range voltages by recalibration. If not, replace faulty resistor.</p>
<p>Measurements are out of tolerance on any range when the Kelvin-Varley divider is dialed to any setting other than <u>499910</u>.</p>	<p>One of the Kelvin-Varley divider resistors is out of tolerance</p>	<p>Measure the voltage drop across each Kelvin-Varley resistor with another John Fluke Differential Voltmeter. Begin by setting RANGE switch to 500 V DC and the voltage dials to 499.910. Reference to the schematic diagram will show that there should be 100, 10, 1, 0.1, and 0.01 volts respectively across each resistor of the A, B, C, D, and E decades, except for the two resistors of each decade that are paralleled by the following decade. Across these two resistors, there should be 50, 5, 0.5, and 0.05 volts, respectively. Measure all voltages $\pm 0.05\%$. Remember that if one resistor in a decade has increased or decreased appreciably, the voltage drop across all other resistors in the decade will be slightly affected also.</p>

Figure 4-3. TROUBLESHOOTING (Sheet 1 of 3)

SYMPTOM	PROBABLE CAUSE	REMEDY
VTVM drift is observed by the need for frequent readjustment of the VTVM-10V-1V zero control.	V203, V204, or V202 are faulty.	Check tubes by replacement in the order specified.
Instrument out of specifications on all ranges except 0.5 V DC when used as a VTVM.	Resistor R116, R114, R112 or R110 out of tolerance.	Check and replace faulty resistor.
Meter rattle, drift, or error is observed in the 0.1V or 0.01V null ranges with or without a voltage applied.	V206 faulty.	Replace V206.
	Mercury cell B201 faulty.	Replace B201.
	V205 faulty.	Replace V205.
	Chopper G1 faulty.	Replace chopper.
NOTE: After any of the above components are replaced, recalibration of the chopper-amplifier gain is necessary. See paragraph 4-4.		
Meter needle offsets to left as voltage dials are increased with NULL switch in the 1V null range, RANGE switch at 500 V DC and no input applied.	Leakage between the VTVM circuit and to 0 volt buss.	Clean instrument as outlined in paragraph 4-2, a.
	If instrument has not been used for a long period of time, leakage may be due to accumulation of moisture.	Leave instrument on for several hours to dry out.
NOTE: The following symptoms are common to AC measurements only, and assume all DC measurements are normal.		
Instrument out of specifications on either 500 VAC or 50 VAC range.	500 VAC or 50 VAC range out of calibration.	Perform AC calibration. If necessary, substitute new converter input attenuator components for the suspected range.
Instrument out of specifications on all AC ranges.	Input voltage is being loaded by capacitor C101.	Reverse input leads.
	V401, V402, V403, or V404 defective.	Check by replacement.
AC readings are in error only at specific frequencies.	SC401 or SC402 defective.	Replace SC401 and/or SC402.

SYMPTOM	PROBABLE CAUSE	REMEDY
<p>Meter rattle, particularly in the 5 VAC range and 0.01V null position.</p>	<p>DC filament voltage on V401 thru V404 too high, caused by defective transistor TR1 or TR302 in converter power supply.</p> <p>Poor electrical contact between the converter and converter power supply printed circuit boards and their respective connectors.</p> <p>Leaky cathode by-pass capacitor on V401, V402, or V403</p>	<p>Check by replacement TR1 and TR302. (Make certain the collector of TR1 does not short to the chassis via the mounting bracket) If the tubes have operated with a filament voltage in excess of 7 V-DC, it is necessary to replace V401, and usually V402 through V404.</p> <p>Check printed circuit board connectors.</p> <p>Check and replace faulty capacitor.</p>

Figure 4-3. TROUBLESHOOTING (Sheet 3 of 3)

- (5) Short input posts and turn NULL switch to 0.01V.
- (6) Adjust R426 for zero meter deflection. A long time constant in this circuit makes this a slow adjustment.
- (7) Turn NULL switch to VTVM, remove the short from the input posts, and set voltage dials to 499910.
- (8) Apply 5 VAC at 400 cycles to the input post.
- (9) Turn NULL switch to 0.01V and adjust the meter to read between 0.2 and 0.4 on the right side of the lower meter scale by adjusting R423.
- (10) Turn NULL switch to VTVM.
- (11) Change 5 VAC 400 cycle input to 5 VAC 10 KC input.
- (12) Turn NULL switch to 0.01V and adjust C8 to indicate same meter deflection as step 9.
- (13) Turn NULL switch to VTVM and RANGE switch to 50 VAC.
- (14) Change input to 50 VAC, 400 cycles.
- (15) Turn NULL switch to 0.01V and using an insulated screwdriver, adjust R3 to indicate same meter deflection as step (9).

- (16) Turn NULL switch to VTVM.
- (17) Change 50 VAC 400 cycle input to 50 VAC 10 KC input.
- (18) Turn NULL switch to 0.01V and adjust C3 with an insulated screwdriver to indicate same meter deflection as step (9).
- (19) Turn NULL switch to VTVM and RANGE switch to 500 VAC.
- (20) Change input to 500 VAC, 400 cycles.
- (21) Turn NULL switch to 0.01V and adjust R7 with an insulated screwdriver to indicate same meter deflection as step (9).
- (22) Turn NULL switch to VTVM.
- (23) Change 500 VAC 400 cycle input to 500 VAC 10 KC input.
- (24) Turn NULL switch to 0.01V and adjust C5 with an insulated screwdriver to indicate same meter deflection as step (9).
- (25) Return the NULL switch to the VTVM position. The AC section of the instrument is now calibrated.

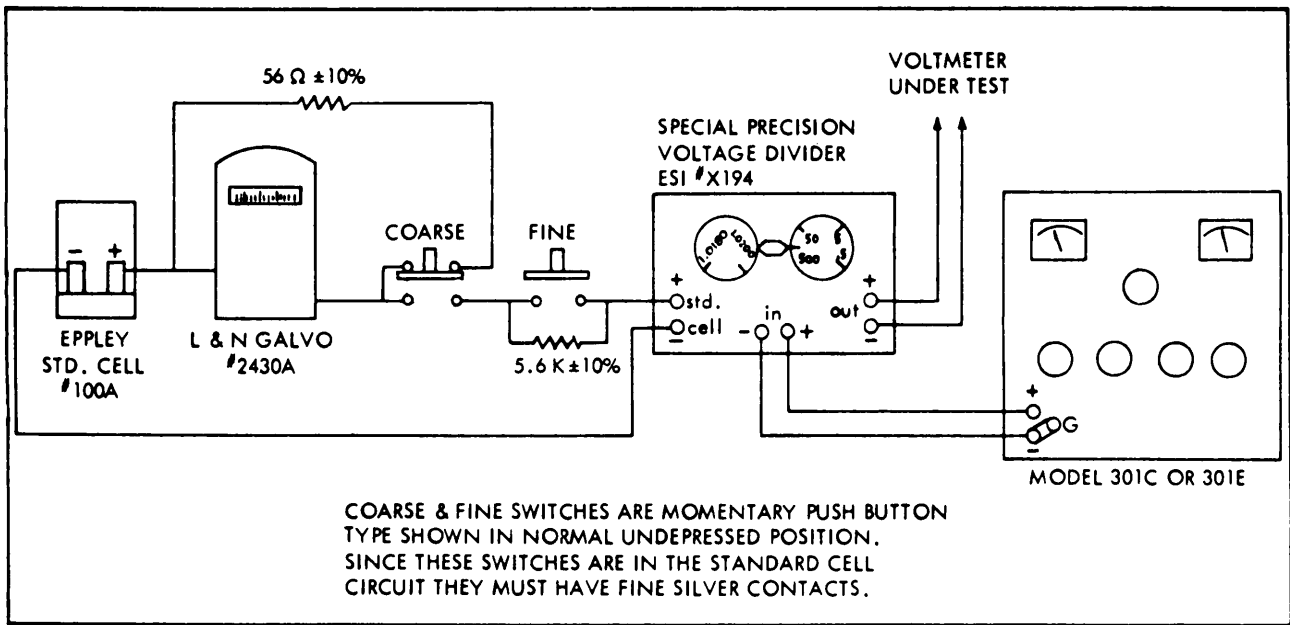

Figure 4-4. DC CALIBRATION SET-UP

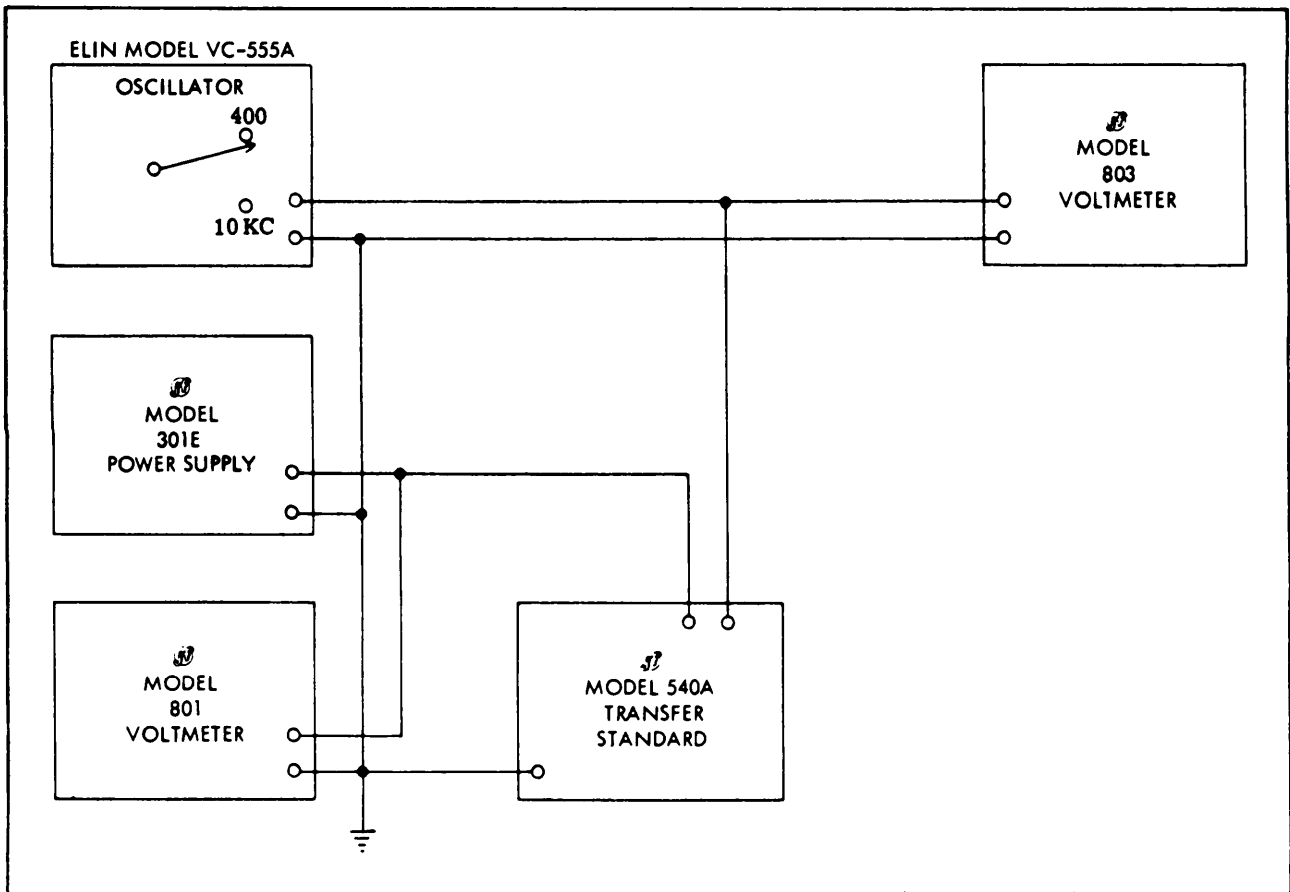

Figure 4-5. AC CALIBRATION SET-UP

SECTION V

LIST OF REPLACEABLE PARTS

The following list of replaceable parts covers all Model 803 voltmeter above serial number 1113 and all Model 803R voltmeters above serial number 406.

The extreme right hand column of the parts list, entitled "Use code," defines the effectivity of the particular part. A list of all "Use Codes" and their effectivity is included at the end of this section.

CIRCUIT SYMBOL	DESCRIPTION	FLUKE STOCK NO.	USE CODE
B1	Standard cell, non-saturated, low hysteresis	X223	
B201	Mercury bias cell, 1.35 V	X44	
C1, C2	Capacitor, oil, 1 mfd, 1000V	CO20	D
C1A, C1B, C1C	Capacitor, electrolytic, 20 mfd, 450V	CE65	E
C3, C5	Capacitor, ceramic, variable, 0.8 - 4.5 mmf	CA4	
C6	Capacitor, ceramic, 300 mmf, 600V	CT13	
C6A	Capacitor, ceramic, 300 mmf, 600V	CT13	
C7	Capacitor, mylar, 0.47 mfd, 600V	CP21	
C8	Capacitor, ceramic, variable, 0.8 - 4.5 mmf	CA4	
C9	Capacitor, ceramic, 20 mmf, 600V	CT14	
C10	Capacitor, paper, 0.1 mfd, 600V	CP5	
C11	Capacitor, paper, 0.1 mfd, 400V	CP4A	
C12	Capacitor, paper, 0.01 mfd, 1600V	CP1	
C13	Capacitor, ceramic, 0.002 mfd, 1000V	CT8	
C14	Capacitor, paper, 0.1 mfd, 600V	CP5	
C101	Capacitor, mylar, 1 mfd, 600V	CP26	
C102	Capacitor, polystyrene, 1 mfd, 200V	CO22	
C103	Capacitor, metalized mylar, 0.47 mfd, 600V	CP25	
C104	Capacitor, electrolytic, 200 mfd, 6 V DC	CE30	A
C105	Capacitor, mylar, 0.1 mfd, 600V	CP20	A
C201, C202	Capacitor, electrolytic, 10/10 mfd, 450V	CE13	
C203	Capacitor, mylar, 0.02 mfd, 600V	CP18	
C204, C205, C206, C207	Capacitor, paper, 0.047 mfd, 400V	CP6	

CIRCUIT SYMBOL	DESCRIPTION	FLUKE STOCK NO.	USE CODE
C208	Capacitor, paper, 220 mmf, 600V	CT1	
C209	Capacitor, paper, 0.047 mfd, 400V	CP6	
C210	Capacitor, paper, 0.01 mfd, 600V	CP7	
C211, C212	Capacitor, mylar, 0.22 mfd, 400V	CP19	
C301	Capacitor, electrolytic, 10/10 mfd, 500V	CE20	
C302	Capacitor, paper, 0.1 mfd, 400V	CP4A	
C303	Capacitor, paper, 0.047 mfd, 400V	CP6A	
C304	Capacitor, electrolytic, 10/10 mfd, 500V	CE20	
C305	Capacitor, paper, 0.1 mfd, 400V	CP4A	
C306	Capacitor, fixed paper, 0.1 mfd, 400V	CP4A	
C307	Capacitor, electrolytic, 8 mfd, 250V	CE10	
C307	Capacitor, electrolytic, 8 mfd, 450V	CE77	I
C308	Capacitor, electrolytic, 4000 mfd, 15V	CE23	
C309	Capacitor, fixed paper, 0.1 mfd, 400V	CP4A	
C310	Capacitor, electrolytic, 8 mfd, 250V	CE10	
C310	Capacitor, electrolytic, 8 mfd, 450V	CE77	I
C311	Capacitor, paper, 220 mmf, 600V	CT1	
C401	Capacitor, electrolytic, 150 mfd, 150V	CE22	
C402	Capacitor, paper, 0.01 mfd, 400V	CP16	
C403	Capacitor, electrolytic, 100 mfd, 6V	CE21	
C404	Capacitor, paper, 0.47 mfd, 200V	CP24	
C405	Capacitor, paper, 0.047 mfd, 400V	CP6A	
C406	Capacitor, electrolytic, 150 mfd, 150V	CE22	
C407	Capacitor, paper, 0.01 mfd, 400V	CP16	
C408	Capacitor, electrolytic, 100 mfd, 6V	CE21	
C409	Capacitor, paper, 0.01 mfd, 400V	CP16	
C410	Capacitor, paper, 0.47 mfd, 200V	CP24	
C411	Capacitor, paper, 0.01 mfd, 400V	CP16	
C413	Capacitor, electrolytic, 100 mfd, 6V	CE21	
C414	Capacitor, ceramic, 680 mmf, 600V	CT3	
C415	Capacitor, mylar, 5 mfd, 200V	CP22	
C416	Capacitor, metalized paper, 2 mfd, 200V	CP14	
C417	Capacitor, metalized paper, 1 mfd, 200V	CP17	

CIRCUIT SYMBOL	DESCRIPTION	FLUKE STOCK NO.	USE CODE
CR1, CR2	Diode, silicon, 50V, 1 Amp.	RE8	
CR3, CR4	Diode, silicon, 280V RMS, 0.3 Amp.	2E4	
CR5, CR6	Diode, silicon, 600 PIV, 0.75 Amp.	RE17	
CR7, CR8	Diode, silicon, 40V, 2 ma	RE7	
CR9	Diode, silicon, 600 PIV, 0.75 Amp.	RE17	
F1	Fuse, 3 Amp.	F3	
F1	Fuse, 1.5 Amp (for 220/234 volt operation)	F1.5	
F101	Fuse, 1/200 Amp. 250V	F1/200A	A
G1	Chopper, SPDT, 6.3V, 60 cycles	X100	
I-103 thru I-108	Lamp, neon, NE2E	X40B	
J101	Binding post, red insulators	X219, X217	
J102	Binding post, black insulators	X219, X218	
J103	Binding post, metal spacer	X219, X220	
M101	Meter, 50-0-50 microamp with special scale	MS1	
R1	Resistor, precision metal film 1 Meg. 1%, 1/2W	DRMF71	
R2	Resistor, precision metal film 122 K, 1%, 1/2W	DRMF61	
R3	Resistor, wirewound, variable 5 K, 10%, 1/4W	P5000TA	
R4, R5	Resistor, precision metal film 500 K, 1%, 1/2W	DRMF63	
R6	Resistor, precision metal film 10 K, 1%, 1/2W	DRMF51	
R7	Resistor, wirewound, variable 500 Ω , 10%, 1/4W	P500T	
R8	Resistor, precision metal film 1 Meg. 1%, 1/2W	DRMF71	
R9	Resistor, precision metal film 200 K, 1%, 1/2W	DRMF62	
R10	Resistor, composition 390 Ω , 10%, 1W	GB3911	
R11	Resistor, composition 470 K, 10%, 1/2W	EB4741	

CIRCUIT SYMBOL	DESCRIPTION	FLUKE STOCK NO.	USE CODE
R12 thru R19	Resistor, composition 22 K, 10%, 2W	HB2231	
R20	Resistor, deposited carbon 500 K, 1%, 2W	DR620	
R21	Resistor, deposited carbon 144 K, 1%, 1W	DR67	
R22	Resistor, composition 39 K, 10%, 1W	GB3931	
R23	Resistor, composition 1 Meg. 10%, 1/2W	EB1051	
R24	Resistor, precision wirewound 149 K, 1/2%, 1W	PR611	
R25	Resistor, composition 1 Meg. 10%, 1/2W	EB1051	
R26, R27	Resistor, deposited carbon 300 K, 1%, 1W	DR614	
R28	Resistor, deposited carbon 250 K, 1%, 1W	DR613	
R29	Resistor, composition 1 Meg. 10%, 1/2W	EB1051	
R30	Resistor, precision wirewound 320 K, 0.1%, 1W	PR614	
R31	Resistor, wirewound, variable 10 K, 10%, 1/4W	P10KTB	
R32	Resistor, precision wirewound 158 K, 0.5%, 1W	PR620	
R33, R34	Resistor, precision wirewound 125 K, 0.1%, 1W	PR610	
R35	Resistor, precision wirewound 509 Ω , 0.1%, 1/2W	PR37	
R36	Resistor, wirewound, variable 5 Ω , 20%, 2W	P5C	
R37	Resistor, wirewound 10 Ω , 5%, 5W	R10WA	
R38 thru R40	Resistor, composition 220 K, 10%, 1W	GB2241	E
R101	Resistor, composition 270 Ω , 10%, 1W	GB2711	
R102	Resistor, composition 15 K, 10%, 1/2W	EB1531	
R103	Resistor, deposited carbon 4.4 Meg. 1%, 1/2W	DR74	

CIRCUIT SYMBOL	DESCRIPTION	FLUKE STOCK NO.	USE CODE
R104	Resistor, deposited carbon 4.5 Meg. 1%, 1/2W	DR75	
R105	Resistor, deposited carbon 4.99 Meg. 1%, 1/2W	DR76	
R106	Resistor, deposited carbon 4.5 Meg. 1%, 1/2W	DR75	
R107	Resistor, deposited carbon 500 K, 1%, 1/2W	DR618	
R108	Resistor, deposited carbon 900 K, 1%, 1/2W	DR622	
R109	Resistor, deposited carbon 103.5 K, 1%, 1/2W	DR63	
R110, R111	Resistor, deposited carbon 9 Meg. 1%, 1/2W	DR78	
R112	Resistor, deposited carbon 900 K, 1%, 1/2W	DR622	
R113	Resistor, deposited carbon 9.9 Meg. 1%, 1/2W	DR79	
R114	Resistor, deposited carbon 90 K, 1%, 1/2W	DR513	
R115	Resistor, deposited carbon 9.99 Meg. 1%. 1/2W	DR711	
R116	Resistor, deposited carbon 10 K, 1%, 1/2W	DR51	
R117	Resistor, wirewound, variable 5 K, 10%, 2W	P5KA	
R118	Resistor, wirewound, variable 10 K, 10%, 2W	P10KA	
R119	Resistor, wirewound, variable 2 K, 10%, 2W	P2KB	G
R119	Resistor, wirewound, variable 1 K, 10%, 2W	P1000A	F
R120, R121	Resistor, precision wirewound 112.375 K, 0.05%, 1W	PR615	
R122	Resistor, composition 27 K, 10%, 1W	GB2731	
R123	Resistor, precision wirewound 28.571 K, 0.05%, 1/2W	PR515	
R124	Resistor, wirewound, variable 500 Ω , 10%, 1/4W	P500T	
R125	Resistor, precision wirewound 2.5317 K, 0.05%, 1/2W	PR49	

CIRCUIT SYMBOL	DESCRIPTION	FLUKE STOCK NO.	USE CODE
R126	Resistor, wirewound, variable 500 Ω , 10%, 1/4W	P500T	
R127	Resistor, precision wirewound 22.5 K, 0.1%, 1/2W	PR513	
R128	Resistor, precision wirewound 250.31 Ω , 0.05%, 1/2W	PR311	
R129	Resistor, wirewound, variable 500 Ω , 10%, 1/4W	P500T	
R130	Resistor, precision wirewound 24.75 K, 0.1%, 1/2W	PR514	
*R131 thru R136	Resistor, precision wirewound 40 K, 0.02%, 1/2W, matched	PR512	
*R137 thru R147	Resistor, precision wirewound 8 K, 0.05%, 1/2W, matched	PR48	
*R148 thru R158	Resistor, precision wirewound 1.8 K, 0.1%, 1/2W, matched	PR48	
*R159 thru R169	Resistor, precision wirewound 320 Ω , 0.1%, 1/2 W, matched	PR39	
*R170 thru R179	Resistor, precision wirewound 64 Ω , 0.1%, 1/2W, matched	PR24	
R180, R181	Resistor, composition 150 K, 10%, 1/2W	EB1541	
R182	Resistor, composition 1 K, 10%, 1W	GB1021	
R183	Resistor, variable 300 Ω , 10%, 2W	P300A	AB
R201, R202	Resistor, composition 56 Ω , 10%, 1W	GB5601	
R203, R204	Resistor, composition 2.7 K, 10%, 1W	GB2721	
R205 thru R209	Resistor, composition 4.7 K, 10%, 1W	GB4721	
R210	Resistor, wirewound, variable 5 K, 10%, 2W	P5MA	
R211, R212	Resistor, deposited carbon 8.2 K, 1%, 1/2W	DR411	
R213, R214	Resistor, composition 1 Meg. 10%, 1/2W	EB1051	
R215	Resistor, composition 10 K, 10%, 1W	GB1031	
R216, R217	Resistor, composition 39 K, 10%, 1W	GB3931	

*These resistors are factory matched for each instrument. When ordering, specify instrument serial number for each resistor ordered.

CIRCUIT SYMBOL	DESCRIPTION	FLUKE STOCK NO.	USE CODE
R218	Resistor, composition 1 Meg. 10%, 1/2W	EB1051	
R219	Resistor, composition 2.2 Meg. 10%, 1/2W	EB2251	
R220	Resistor, composition 1 Meg. 10%, 1/2W	EB1051	
R221	Resistor, deposited carbon 2.2 Meg. 1%, 1/2W	DR73	
R222	Resistor, composition 10 Meg. 10%, 1/2W	EB1061	
R223	Resistor, composition 1 Meg. 10%, 1/2W	EB1051	
R224	Resistor, wirewound, variable 10 K, 10%, 2W	P10KA	
R225	Resistor, deposited carbon 5 K, 1%, 1/2W	DR49	
R226, R227	Resistor, composition 220 K, 10%, 1/2W	EB2241	
R228	Resistor, composition 2.2 Meg. 10%, 1/2W	EB2251	
R303	Resistor, composition 150 K, 10%, 1/2W	EB1541	
R304	Resistor, composition 220 K, 10%, 1/2W	EB2241	
R305	Resistor, composition 150 K, 10%, 1/2W	EB1541	
R306	Resistor, deposited carbon 250 K, 1%, 1W	DR613	
R307	Resistor, deposited carbon 125 K, 1%, 1/2W	DR629	
R308	Resistor, composition 1 Meg. 10%, 1/2W	EB1051	
R309, R310	Resistor, composition 680 K, 10%, 1/2W	EB6841	
R311	Resistor, composition 1 Meg. 10%, 1/2W	EB1051	
R312	Resistor, deposited carbon 45 K, 1%, 1W	DR56	
R313	Resistor, deposited carbon 90 K, 1%, 1/2W	DR513	
R314	Resistor, composition 470 K, 10%, 1/2W	EB4741	

CIRCUIT SYMBOL	DESCRIPTION	FLUKE STOCK NO.	USE CODE
R315	Resistor composition 100 K, 10%, 1/2W	EB1041	
R316	Resistor, composition 1 Meg. 10%, 1/2W	EB1051	
R317	Resistor, deposited carbon 100 K, 1%, 1/2W	DR61	
R318	Resistor, deposited carbon 40 K, 1%, 1W	DR57	
R319	Resistor, deposited carbon 90 K, 1%, 1/2W	DR513	
R320, R321	Resistor, composition 150 K, 10%, 1/2W	EB1541	
R322	Resistor, deposited carbon 3.89 K, 1%, 1/2W	DR414	
R323	Resistor, deposited carbon 50 K, 1%, 1/2W	DR59	
R324, R325	Resistor, composition 10 K, 10%, 1W	GB1031	
R326	Resistor, composition 15 K, 10%, 1W	GB1531	
R327	Resistor, wirewound 7.5 Ω , 5%, 5W	R7.5W	
R328	Resistor, composition 10 K, 10%, 1/2W	EB1031	A
R401	Resistor, composition 3.3 K, 10%, 1W	GB3321	
R402	Resistor, composition 1.5 K, 10%, 1W	GB1521	
R403	Resistor, composition 220 Ω , 10%, 1/2W	EB2211	
R404, R405	Resistor, composition 2.2 Meg. 10%, 1/2W	EB2251	
R406	Resistor, composition 1 Meg. 10%, 1/2W	EB1051	
R407, R408	Resistor, composition 3.3 K, 10%, 1W	GB3321	
R409	Resistor, composition 220 Ω , 10%, 1/2W	EB2211	
R410, R411	Resistor, composition 10 Meg. 10%, 1/2W	EB1061	
R412	Resistor, composition 360 Ω , 5%, 1W	GB3615	

CIRCUIT SYMBOL	DESCRIPTION	FLUKE STOCK NO.	USE CODE
R413	Resistor, composition 1 Meg. 10%, 1/2W	EB1051	
R414	Resistor, composition 27 K, 10%, 1W	GB2731	
R415	Resistor, composition 560 Ω , 10%, 1/2W	EB5611	
R416	Resistor, composition 100 Ω , 10%, 1/2W	EB1011	
R417 thru R419	Resistor, composition 33 K, 10%, 1W	GB3331	
R420, R421	Resistor, precision metal film 22 K, 1%, 1/2W	DRMF52	
R422	Resistor, precision metal film 2.4 K, 1%, 1/2W	DRMF42	
R423	Resistor, wirewound, variable 100 Ω , 10%, 1/4W	P100T	
R424, R425	Resistor, deposited carbon 50 K, 1%, 1/2W	DR59	
R426	Resistor, wirewound, variable 5 K, 10%, 1/4W	P5000T	
R427	Resistor, composition 220 Ω , 10%, 1/2W	EB2211	
R428, R429	Resistor, composition 10 Ω , 10%, 1W	GB1001	
R430	Resistor, composition 1 K, 10%, 1W	GB1021	
S101	Switch, rotary, 3 pole, 4 position Cabinet Model 803 Rack Model 803	803-808 803R-804	
S102	Switch, rotary, 10 pole, 7 position	SR39	
S103	Switch, rotary, 6 pole, 5 position	SR29	
S104	Switch, rotary, 2 pole, 5 position	SR40	
S105, S106 S107	Switch, rotary, 2 pole, 10 position	SR41	
S108	Switch, rotary, 2 pole, 11 position	SR42	
T1	Transformer assembly, harnessed Cabinet Model 803 Rack Model 803	803-611 803R-611	
TR1	Transistor, power	2N301W	D
TR1	Transistor, power	2N285A	E

CIRCUIT SYMBOL	DESCRIPTION	FLUKE STOCK NO.	USE CODE
TR301, TR302	Transistor, NPN junction	2N214	
V1	Vacuum tube Rectifier, 5AR4	5AR4	C
V1	Vacuum tube rectifier, 5Y3GT	5Y3GT	B
V2	Vacuum tube pentode, 6AQ5A	6AQ5A	
V3	Vacuum tube pentode, 6AU6	6AU6	
V4	Vacuum tube voltage regulator, OA2	OA2	
V5	Vacuum tube duo triode, 12AU7	12AU7	
V6, V7	Vacuum tube voltage reference, OG3	OG3	
V8	Vacuum tube duo triode, 12AX7	12AX7	
V9, V201	Vacuum tube current regulator, 9-7	9-7	
V202	Vacuum tube voltage regulator, OA2	OA2	
V203	Vacuum tube voltage regulator, OB2	OB2	
V204	Vacuum tube duo triode, 12AU7	12AU7	
V205	Vacuum tube triode, 6C4	6C4	
V206	Vacuum tube duo triode, 12AX7	12AX7	
V301	Vacuum tube rectifier, 6X4	6X4	
V302	Vacuum tube beam power, 5881	5881	
V303	Vacuum tube triode-pentode, 6AW8	6AW8	
V304	Vacuum tube duo triode, 12AX7	12AX7	
V305	Vacuum tube pentode, 6AQ5A	6AQ5A	
V306	Vacuum tube triode-pentode, 6AW8	6AW8	
V307	Vacuum tube voltage reference, OG3	OG3	
V308	Vacuum tube voltage regulator, OA2	OA2	
V309	Vacuum tube voltage reference, OG3	OG3	
V310	Lamp, neon, NE2E	NE2E	
V401, V402, V403	Vacuum tube pentode, 6DK6	6DK6	
V404	Vacuum tube duo triode, 12AU7	12AU7	
	Connector, 18 pin female	X150	
	Connector, 10 pin female	X151	
	Connector, 24 pin female	X254	
	Connector, 9 pin male	X149	

CIRCUIT SYMBOL	DESCRIPTION	FLUKE STOCK NO.	USE CODE
	Connector, 4 pin female	X177	
	Connector, 24 pin male	X255	
	Connector, 9 pin female	X153	
	Connector, 4 pin male	X178	
	Cord, power	X27D	
	Feet, rubber mounting	X224	
	Fuse holder	X12	
	Knob, 1-1/2" with pointer	X234	
	Knob, 1-1/2" without pointer	X207	
	Knob, 1" with pointer	X281	

USE ON EFFECTIVITY

The following list of "Use Codes" is intended to allow the customer to determine the effectivity of all replaceable parts. Note that parts with no code are used on all 803 voltmeters above serial 1113, and all 803R voltmeters above serial number 406.

USE CODE

No Code	Model 803 serial number 1113 and on Model 803R serial number 406 and on
A	Model 803 serial number 1488 and on Model 802R serial number 610 and on
B	Model 803 serial number 1113 thru 1500 Model 803R serial number 610 thru 745

USE CODE

C	Model 803 serial number 1500 and on Model 803R serial number 610 and on
D	Model 803 serial number 1113 thru 2110 Model 803R serial number 610 thru 835
E	Model 803 serial number 2110 and on Model 803R serial number 835 and on
F	Model 803 serial number 1113 thru 2170 Model 803R serial number 610 thru 845
G	Model 603 serial number 2170 and on Model 80SR serial number 045 and on
H	Model 803 serial number 1113 thru 2244 Model 803R serial number 610 thru 875
I	Model 803 serial number 3150 and on Model 803R serial number 1136 and on

EFFECTIVITY

By Order of the Secretary of the Army:

EARLE G. WHEELER,
General, United States Army,
Chief of Staff.

Official:

J.C. LAMBERT,
Major General, United States Army,
The Adjutant General.

Distribution:

Active Army:

DASA (6)
USASA (2)
CNGB (1)
CSigO (7)
CofEngrs (5)
CofT (5)
TSG (5)
USCONARC (5)
ARADCOM (2)
ARADCOM Rgn (2)
OS Maj Comd (3)
OS Base Comd (2)
LOGCOMD (2)
MDW (1)
Armies (2)
Corps (2)
USATC Armor (2)
USATCI AD (2)
USATU Inf (2)
USATC Engrs (2)D
USATC FA (2)
Ft Monmouth (63)
USA Msl Comd (4)
Svc College (2)

Br Svc Sch (2)
GENDEP (OS) (2)
Sig Sec, GENDEP
(OS) (5)
Army Dep (2) except
Atlanta (none)
Sacramento (17)
Sig Dep (OS) (12)
Instls (2)
WRAMC (1)
Trans Tml Cored (1)
Army Tml Cored (1)
POE (1)
OSA (1)
USA Elct Comd (5)
USAEPG (2)
AFIP (1)
AMS (1)
Army Pic Cen (2)
EMC (1)
Yuma Test Sta (2)
USA Elct Mat Agcy (25)
Chicago Proc Dist (1)
USA Carib Sig Agcy (1)

USA Sig Msl Spt Agcy (13)
Sig Fld Maint Shop (3)
USA Strat Comm Cored (4)
Def Tfc Mat Svc (1)
Def Sup Spt Cen (1)
USA Corps (3)
JBUSMC (2)
Units organized under following
TOE's: 2 copies each unless
otherwise indicated:
11-7
11-16
11-57
11-97
11-98
11-117
11-155
11-157
11-500 (AA-AE) (4)
11-557
11-587
11-502
11-507

NG: State AG (8).

USAR: None.

For explanation of abbreviations used, see AR 320-50.

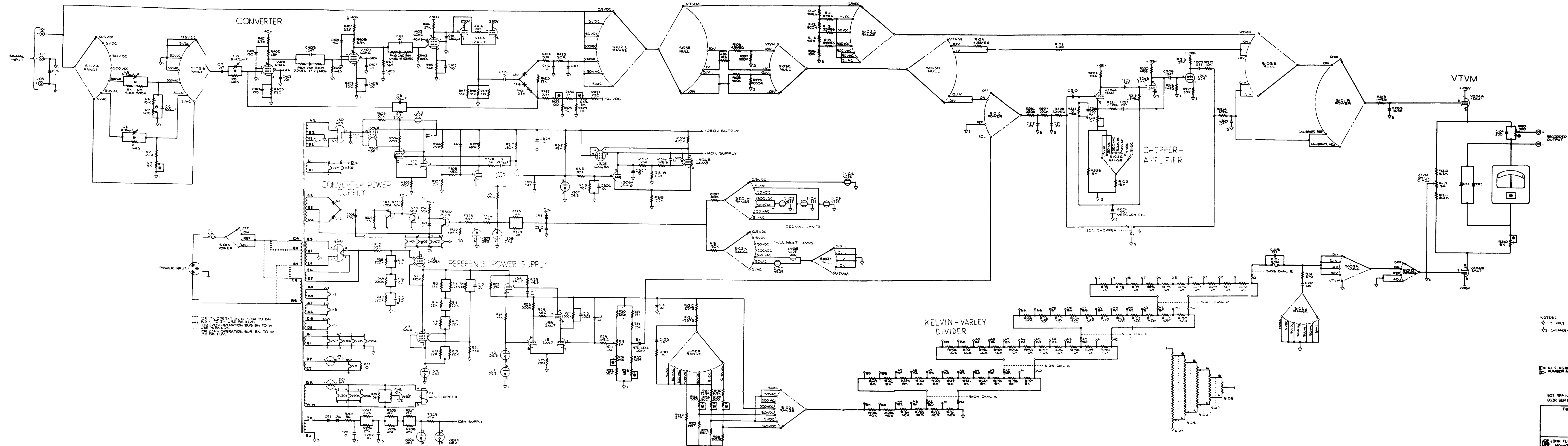

* IS OPERATION BUS BK TO BN
 ** IS OPERATION BUS BN TO W
 *** IS OPERATION BUS BN TO W
 **** IS OPERATION BUS BN TO W

NOTES:
 * = VOLT BUS
 ** = CHOPPER-AMP, VTVM COMMON

ALL TAG NOTES WITH THE SAME
 NUMBER ARE CONNECTED.

803 REF NO. 27-16 CN
 803R SER NO. R 178 CN

FUNCTIONAL SCHEMATIC
 AC/DC
 DIFFERENTIAL
 VOLTMETER
 MODEL 803, 803R
 JOHN FLUE MANUFACTURING COMPANY
 MOUNTLAKE TERRACE, WASHINGTON

